



MARINE
PRODUCTS
COLLECTION

NAVICO™ GROUP

TAKING YOU FURTHER

Navico Group is the world's leading supplier of integrated systems and products to industries ranging from marine to recreational vehicle and beyond. We offer an unmatched portfolio comprised of industry-leading brands in power management, digital control & monitoring, networked devices and marine electronics.

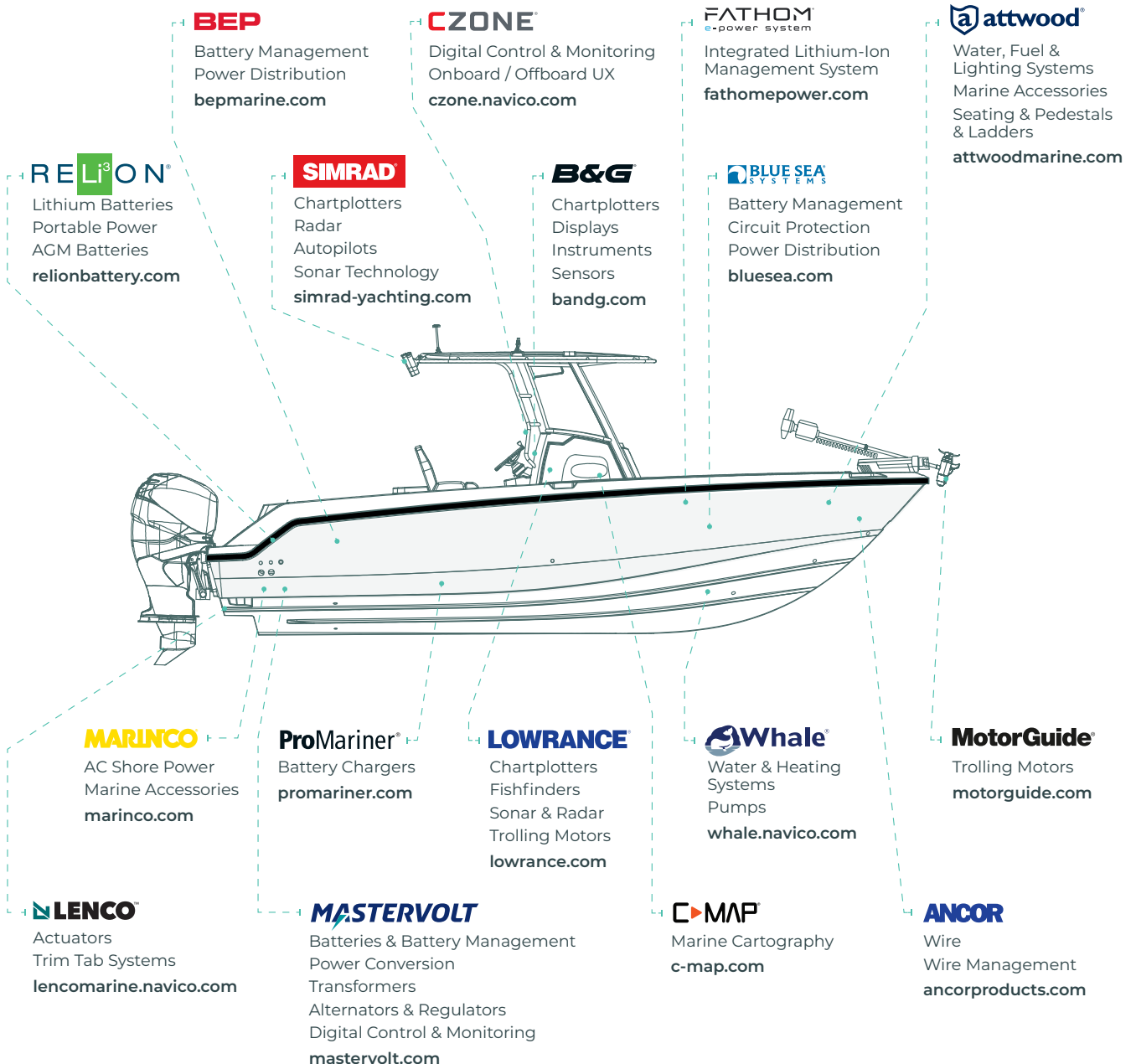

See how far our innovations can take you at Navico.com



Founders Vision

In 1810, Munster Simms Engineering was established as a distribution and petroleum company. The business has undergone many changes since, moving to manufacturing brass bilge pumps for the Royal Navy during the Second World War in 1939, launching pumps to the Marine sector in the 1940s and then supplying pumps and taps to the RV market in the 1960s. Fast forward 60 years and Whale now supply a comprehensive range of water systems, water heating systems and space heating solutions across a range of mobile applications.



Innovation

Award winning innovative products; designed and manufactured to deliver the highest standards of performance and safety, enhancing the user experience.



Quality

Relentless pursuit to exceed consumer expectations through continuous improvement in the design, product quality and service.

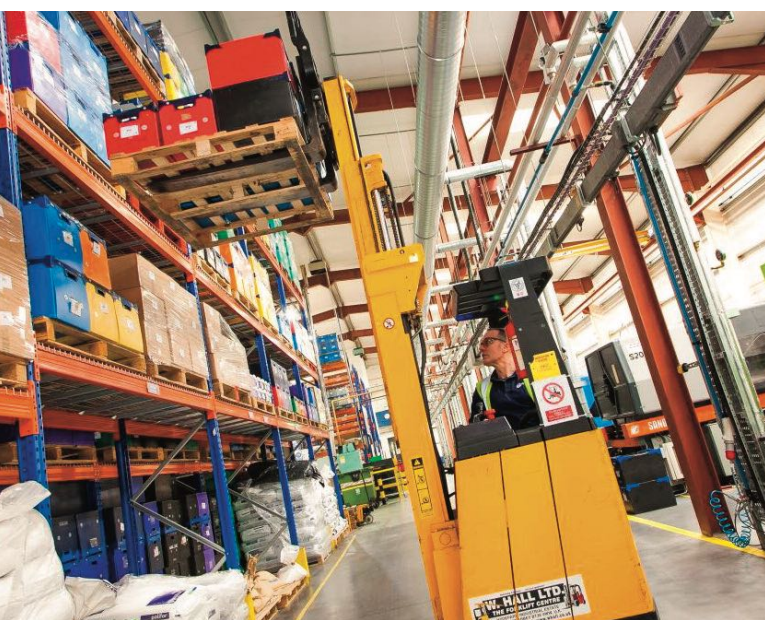

Service

Best in class, friendly, transparent support throughout the consumer journey. Always prepared to go the extra mile.



ELECTRIC BILGE

Supersub Smart	08-09
Supersub	10-11
Orca Auto	12-13
Orca	14-15
Bilge IC	16-17
Gulper 320	18-19



MANUAL BILGE

Gusher 10	22-23
Gusher 30	24-25
Gusher Urchin	26-27
Gusher Titan	28-29
MK5 Universal Range	30-31
Compac 50	32-33
Smartball	34-35
Easybailer	36-37
Bilge Accessories	38-41



FRESHWATER

Watermaster	44-45
Submersible and Inline	46-47
Accumulator Pump Kit	48-49
High Capacity Freshwater Kit	50-51
V Pump MK7	52-53
Flipper Pump MK4	54-55
Gusher Galley MK3	56-57
Babyfoot	58-59



WATER HEATERS

12V d.c. Water Heater	62
AC Water Heaters	63-65



SHOWERS AND FAUCETS

Elegance Faucet Range	68
Interior Showers - Elegance	69
Whale Twist Deck Shower	70-71
Swim 'N' Rinse Compact Deck / Transom Shower	72
Swim 'N' Rinse Transom Shower	73
Fresh Accessories	74-75



WASH DOWN

High Pressure Wash Down Range	78-79
Portable Pump Kit	80
Watertight Locker Doors / Deck Hatches	81

WASH DOWN



PLUMBING

Quick Connect Pipework and Fittings	82-85
-------------------------------------	-------

PLUMBING



FISH BOX/LIVEWELL

Gulper Grouper	88-89
Gulper 320	90-91

FISH BOX/LIVEWELL



GRAY WASTE

Manifold IC	94-95
Gulley IC	96-97
Gulper 320	98-99
Gulper 220	100-101
Gray Waste Tanks	102-103
Shower and Sink Waste High Capacity System	104
Shower and Sink Waste System	105
Gray / Shower Waste Accessories	106-107

GRAY WASTE



BLACK WASTE

Gulper Toilet Pump	110-111
MK5 Manual Sanitation Pump	112-113
Black / Toilet Waste Accessories	114-115

BLACK WASTE

PUMP SELECTION

116-122

DISCLAIMER

123

DISTRIBUTORS

124-126





AWARD WINNING ELECTRIC PUMPS FROM THE EXPERTS IN BILGE SYSTEMS

From the iconic Gusher range to the original low profile Supersub, Whale have always led the way in everything bilge.

From ground-breaking pump and water system designs through to recent innovative leaps in electronically controlled systems, Whale offers peace of mind.

THE ORIGINAL, AWARD-WINNING, LOW PROFILE, NARROW, AUTOMATIC ELECTRIC BILGE PUMP PROVEN OVER 20 YEARS

- ▶ No separate bilge switch required
- ▶ Low profile design is ideal for narrow bilge
- ▶ Retrofittable with angled mounting bracket to aid installation
- ▶ Low power consumption
- ▶ Suitable for use in fresh and saltwater
- ▶ Integrated bleed ball prevents air locks

	Supersub Smart		
Model	Supersub Smart 650 (with non return valve)	Supersub Smart 1100 (with non return valve)	Supersub Smart 1100 (with non return valve)
PART NUMBER	SS5212	SS1212	SS1224
Weight	0.3kg (0.7lbs)	0.5kg (1.0lbs)	0.5kg (1.0lbs)
Voltage	12V d.c.	12V d.c.	24V d.c.
Fuse size	5 amps	5 amps	2.5 amps
Cable size	1.5mm ² (16AWG)		
Hose connection	19mm (¾") / 25mm (1") stepped port	25mm (1") / 28mm (1⅛") stepped port	25mm (1") / 28mm (1⅛") stepped port
Materials	Pump Body: Polypropylene, High Temperature ABS, Fully Potted Circuitry. Locking Ring: Acetal, Impeller: Glass-Filled PBT, Seals: Nitrile, Fasteners: Stainless Steel		
Materials in contact with fluid	Polypropylene, ABS, Glass-Filled PBT, Nitrile		

	Performance		
PART NUMBER	SS5212	SS1212	SS1224
Max discharge head	3m (10ft)		
Open flow rate	40 ltrs/min (650 US GPH)	66 ltrs/min (1050 US GPH)	
Open flow rate at 1m (3ft) head	34 ltrs/min (550 US GPH)	47 ltrs/min (750 US GPH)	

For further guidance on the selection of the correct pump, please see page 118

WARRANTY 3 YEARS

- ▶ CE Certified
- ▶ ISO 8849
- ▶ ISO 15083
- ▶ ISO 8846
- ▶ ISO 10133
- ▶ ABYC H-22
- ▶ NMMA Type Certified



QUALITEC TECHNOLOGY AWARD

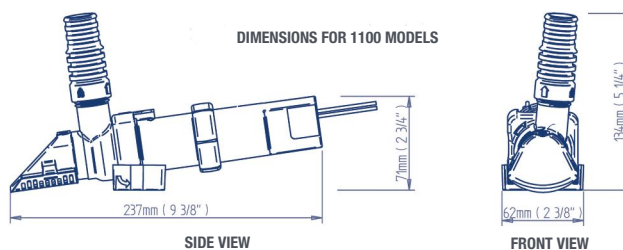
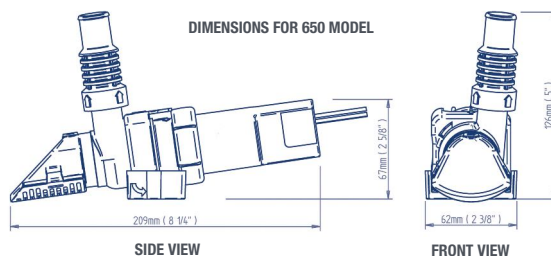
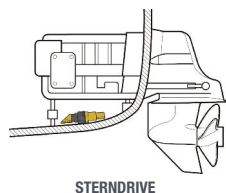
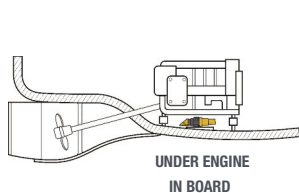
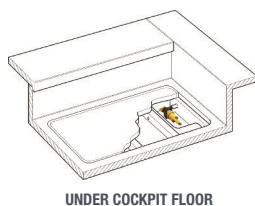
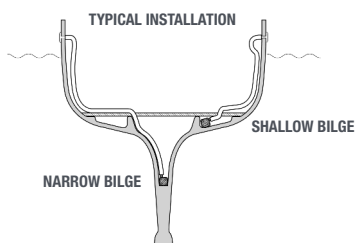

DESIGNED TO FIT IN NARROW BILGE SPACES WHERE OTHERS DO NOT REACH

- ▶ Easy installation - outlet and pump body rotate to suit your installation
- ▶ Easy maintenance with unique easy clean strainer
- ▶ Efficient operation - low power consumption
- ▶ Low profile strainer leaves bilge almost dry
- ▶ Integrated bleed ball prevents air locks

	Supersub			
MODEL	Supersub 500	Supersub 650 (with non return valve)	Supersub 1100 (with non return valve)	Supersub 1100 (with non return valve)
PART NUMBER	SS5012	SS5022	SS1012	SS1024
Weight	0.27kg (0.6lbs)		0.4kg (0.9lbs)	
Voltage	12V d.c.			24V d.c.
Fuse size	5 amps			2.5 amps
Cable size	1.5mm ² (16AWG)			
Hose connection	19mm (¾")	19mm (¾") / 25mm (1") stepped port	25mm (1") / 28mm (1½") stepped port	
Materials	Pump Body: Polypropylene, High Temperature ABS, Fully Potted Circuitry. Locking Ring: Acetal, Impeller: Glass-Filled PBT, Polypropylene, Seals: Nitrile, Fasteners: Stainless Steel			
Materials in contact with fluid	Polypropylene, ABS, Glass-Filled PBT, Nitrile			
Accessories	Electric bilge switches BE9003 and BE9006, for all bilge accessories see page 38-40, Non return valve LV1219			

	Performance		
PART NUMBER	SS5012	SS5022	SS1012 / SS1024
Max discharge head	3m (10ft)		
Open flow rate	32 ltrs/min (500 US GPH)	40 ltrs/min (650 US GPH)	66 ltrs/min (1050 US GPH)
Open flow rate at 1m (3ft) head	25 ltrs/min (400 US GPH)	34 ltrs/min (550 US GPH)	47 ltrs/min (750 US GPH)

For further guidance on the selection of the correct pump, please see page 117

WARRANTY 3 YEARS

- ▶ CE Certified
- ▶ ISO 8849
- ▶ ISO 15083
- ▶ ISO 8846
- ▶ ISO 10133
- ▶ ABYC H-22
- ▶ NMMA Type Certified



500

650

1100

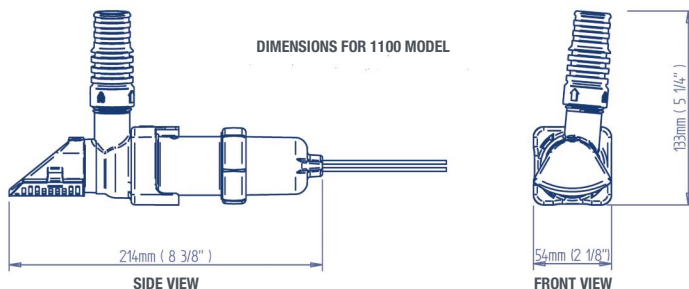
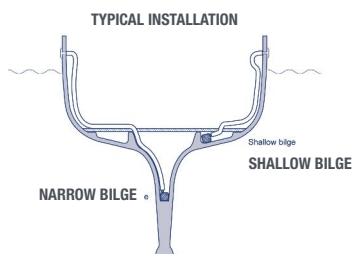
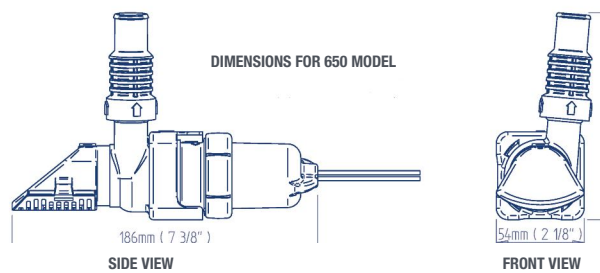
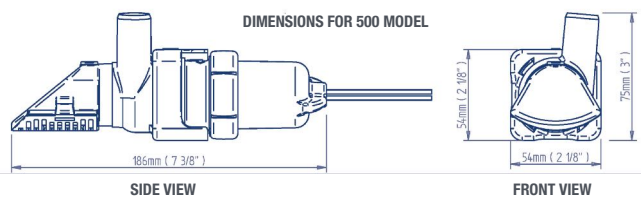

COMPACT, POWERFUL AND AUTOMATIC

- ▶ Simple to install, built-in automatic sensor. No separate bilge switch required
- ▶ Low current draw means longer battery life
- ▶ Efficient - large filter ensures maximum surface area exposed to bilge water
- ▶ Neat fit in compact bilge areas
- ▶ Easy maintenance - simply unclip cover to maintain

Model	Orca Auto 1300	
PART NUMBER	BE1482	BE1484
Weight	0.9kg (2.0lbs)	
Voltage	12V d.c.	24V d.c.
Fuse size	7.5 amps	5 amps
Cable size	1.5mm ² (16AWG)	
Hose connection	25mm (1") / 28mm (1½") stepped port	
Materials	Pump Body: ABS, Seals: Nitrile, Impeller: Acetal	

	Performance
PART NUMBER	BE1482 / BE1484
Max discharge head	4.5m (14.8ft)
Open flow rate	82 ltrs/min (1300 US GPH)
Flow rate at 1m (3ft) head	65 ltrs/min (1100 US GPH)

For further guidance on the selection of the correct pump, please see page 118

COMPACT, EFFICIENT DESIGN

- ▶ Easy installation - outlet and pump body rotate to suit your installation
- ▶ Easy to maintain - unique easy clean strainer
- ▶ Low current draw means longer battery life
- ▶ Neat fit in compact bilge areas

	Orca		
Model	Orca 2000	Orca 2000	Orca 3000
PART NUMBER	BE2002	BE2004	BE3004
Weight	1.32kg (2.9lbs)		2.64kg (5.8lbs)
Voltage	12V d.c.	24V d.c.	24V d.c.
Fuse size	15 amps	7.5 amps	15 amps
Cable size	1.5mm ² (16AWG)		
Hose connection	28mm (1½")		32mm (1¼")
Materials	Pump Body: ABS, Seals: Nitrile, Impeller: Acetal		
Accessories	Electric bilge switches BE9003 and BE9006, for all bilge accessories see page 38-40		

	Performance	
PART NUMBER	BE2002 / BE2004	BE3004
Max discharge head	4m (13ft)	4.6m (15ft)
Open flow rate	126 ltrs/min (2000 US GPH)	189 ltrs/min (3000 US GPH)
Flow rate at 1m (3ft) head	104 ltrs/min (1650 US GPH)	170 ltrs/min (2700 US GPH)

For further guidance on the selection of the correct pump, please see page 117

WARRANTY 3 YEARS

- ▶ CE Certified
- ▶ ISO 8849
- ▶ ISO 15083
- ▶ ISO 8846
- ▶ ISO 10133
- ▶ ABYC H-22
- ▶ NMMA Type Certified



2000



3000

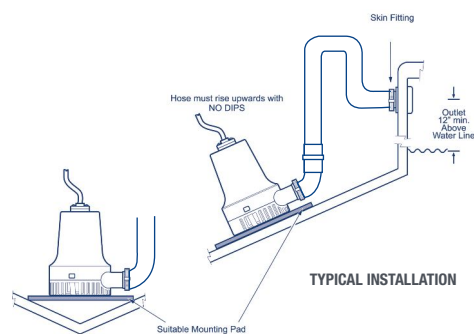

TYPICAL INSTALLATION

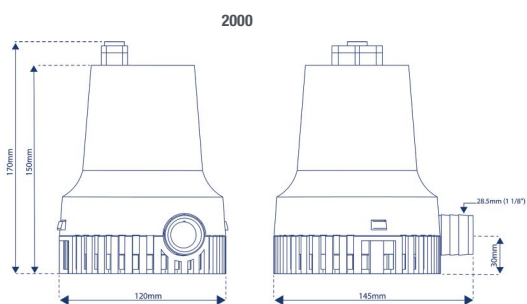

2000

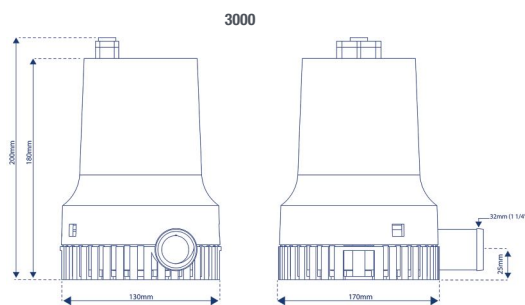

3000

PRE-WIRED REMOTE MOUNTED BILGE SYSTEM (4 IN 1) WITH AUTOMATIC INTELLIGENT CONTROL

- ▶ Small footprint strainer with integrated sensor fits into confined spaces
- ▶ Remote mounted pump with integrated electronics - intelligent control
- ▶ Multi directional head for easy installation
- ▶ Low current draw means longer battery life
- ▶ Override wire included for manual activation

Model	Bilge IC	
PART NUMBER	SI8284	SI8484
Weight	2.6kg (6.5lbs)	
Voltage	12V d.c.	24V d.c.
Fuse size	10 amps	5 amps
Cable size	1.5mm ² (16AWG)	
Cable length	4m (13ft)	
Hose connection	Barbed Connections Gulper IC 19mm (¾") or 25mm (1"), Strainer IC 19mm (¾")	
Materials	Pump Head: Glass-filled Nylon, Valves: Nitrile, Diaphragm: Santoprene®	
Materials in contact with fluid	Glass-filled Nylon, Nitrile, Santoprene®	
Service kits	AK2050 - Replacement Pump Head, AS1562 - Clamping Ring	

	Performance			
PART NUMBER	SI8284 / SI8484			
Hose size	19mm (¾")	25mm (1")	19mm (¾")	25mm (1")
Suction lift	0m (0ft)	0m (0ft)	1m (3ft)	1m (3ft)
Discharge head	1m (3ft)	1m (3ft)	1m (3ft)	1m (3ft)
Flow rate	19 ltrs/min (300 US GPH)	17.5 ltrs/min (276 US GPH)	17.4 ltrs/min (270 US GPH)	15.5 ltrs/min (246 US GPH)

For further guidance on the selection of the correct pump, please see page 118

WARRANTY 3 YEARS

- ▶ CE Certified
- ▶ ISO 8849
- ▶ ISO 15083
- ▶ ISO 8846
- ▶ ABYC H-22

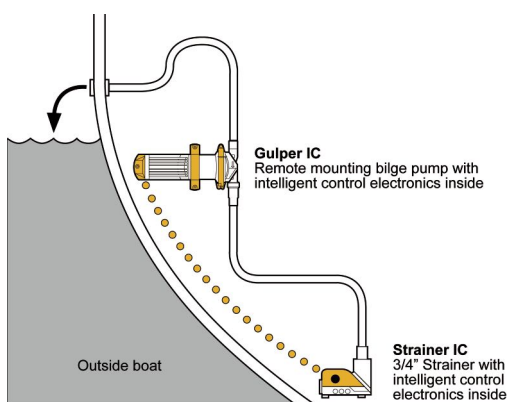

TYPICAL INSTALLATION

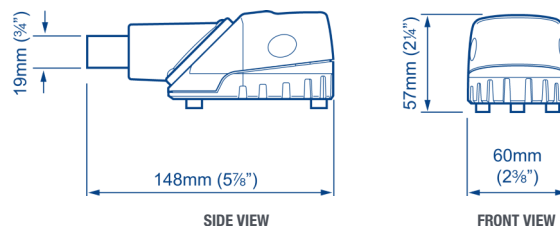
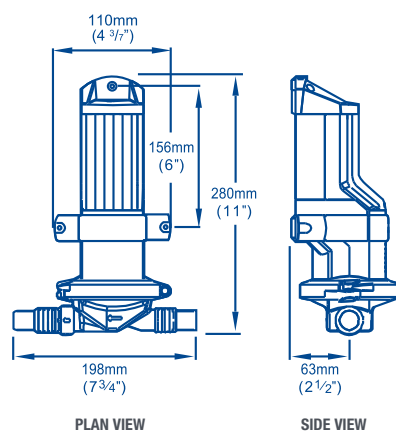

EASY ACCESS REMOTE BILGE PUMP FOR PROTECTION AND EASY INSPECTION

- ▶ Remote mount pump for easy access
- ▶ Low current draw means longer battery life
- ▶ Multi directional head for easy installation
- ▶ Easy maintenance - non-choke valve, no filter to block or clean
- ▶ Self-primers and can run dry without damage

Model	Gulper 320	
PART NUMBER	BP2052	BP2054
	Includes 19mm (¾") strainer	
Weight	1.6kg (3.5lbs)	
Voltage	12V d.c.	24V d.c.
Fuse size	10 amps	5 amps
Cable size	1.5mm ² (16AWG)	
Hose connection	19mm (¾") or 25mm (1")	
Materials	Pump Head: Glass-Filled Nylon, Valves: Nitrile, Diaphragm: Santoprene®	
Accessories	SB3422 19mm (¾") strainer (multi-directional port)	
Service kits	AK2050 - Replacement Pump Head, AS1562 - Clamping Ring	

	Performance			
PART NUMBER	BP2052 / BP2054			
Max suction lift	3m (10ft)			
Max discharge head	3m (10ft)			
Discharge head and suction lift combined	4m (13ft)			
Hose size	19mm (¾")	25mm (1")	19mm (¾")	25mm (1")
Suction lift	0m (0ft)	0m (0ft)	1m (3ft)	1m (3ft)
Discharge head	1m (3ft)	1m (3ft)	1m (3ft)	1m (3ft)
Flow rate	19 ltrs/min (300 US GPH)	17.5 ltrs/min (276 US GPH)	17.5 ltrs/min (276 US GPH)	15.5 ltrs/min (246 US GPH)

WARRANTY 3 YEARS

- ▶ CE Certified
- ▶ ISO 8849
- ▶ ISO 15083
- ▶ ISO 8846
- ▶ ABYC H-22



EASY ACCESS FOR INSPECTION

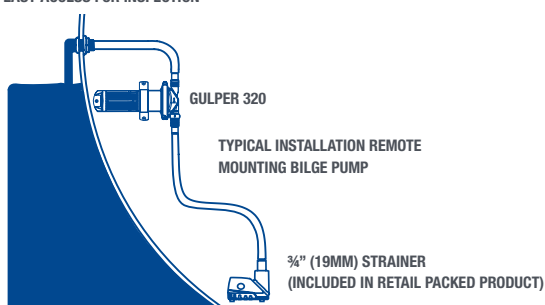

STRAINER

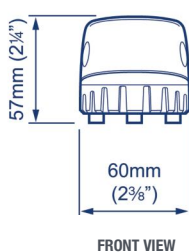
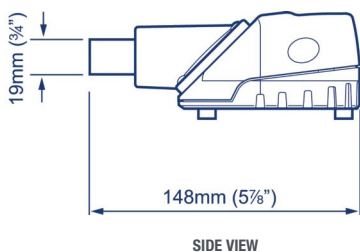

GULPER

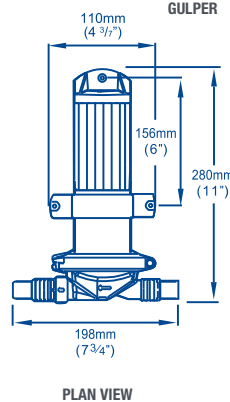

MANUAL BILGE





OVER 70 YEARS OF PROVEN EXPERTISE IN MANUAL BILGE

Since 1940, Whale's range of tough, long-life manual bilge systems have put safety and reliability first. Today, our extensive offering includes manual pumps for all boat sizes and needs, along with accessories for the complete system.

THE ORIGINAL BILGE PUMP CHOICE FOR SAILORS IN EXTREME CONDITIONS

- ▶ Top performance 65 ltrs/min (17 US Gals)
- ▶ High flow non-choke valves, no filter to block or clean
- ▶ Mounting options - on deck, thru deck, bulkhead
- ▶ Designed for easy installation and maintenance
- ▶ Easy pump action

Model	Gusher 10	
	On Deck / Bulkhead	Thru Deck / Bulkhead
PART NUMBER	BP3708	BP3740
Weight	2.3kg (5.0lbs)	
Hose connection	38mm (1½")	
Materials	Pump Body: Marine Grade LM6 Aluminium Alloy (epoxy coated), Diaphragm: Neoprene (Nitrile option available), Fasteners: Stainless Steel	
Materials in contact with fluid	Marine Grade LM6 Aluminium Alloy (Epoxy Coated), Neoprene, Nitrile, Stainless Steel	
Service kits	AS4405 - Spare Handle, DP8904 - Plastic Deck Plate Lid, DP3804 - Alloy Deck Plate	
Accessories	AS4405 - Spare Handle	

	Performance	
PART NUMBER	BP3708 / BP3740	
Maximum suction lift	4m (13ft)	
Maximum discharge head	4m (13ft)	
Suction lift	1m (3ft)	2m (6ft)
Discharge head	0.5m (1.5ft)	0.5m (1.5ft)
45 Strokes per minute	41 ltrs/min (11 US Gals)	41 ltrs/min (11 US Gals)
70 Strokes per minute	65 ltrs/min (17 US Gals)	65 ltrs/min (17 US Gals)

For further guidance on the selection of the correct pump, please see page 119

WARRANTY 5 YEARS

- ▶ Suitable as a primary bilge pump on boats equal to or greater than 24m (80ft) in accordance with ISO 15083



GUSHER 10 MK3
THRU DECK/BULKHEAD
BP3740

Skin fitting 38mm (1½") SF5425

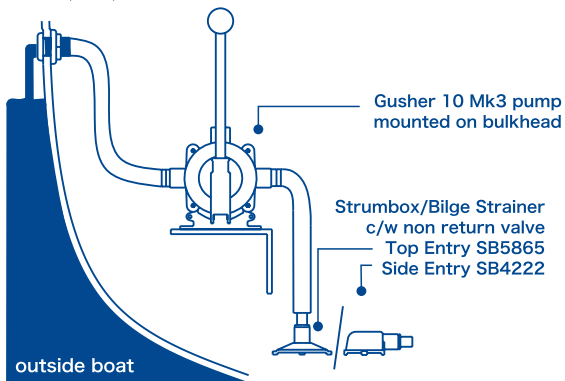

TYPICAL INSTALLATION

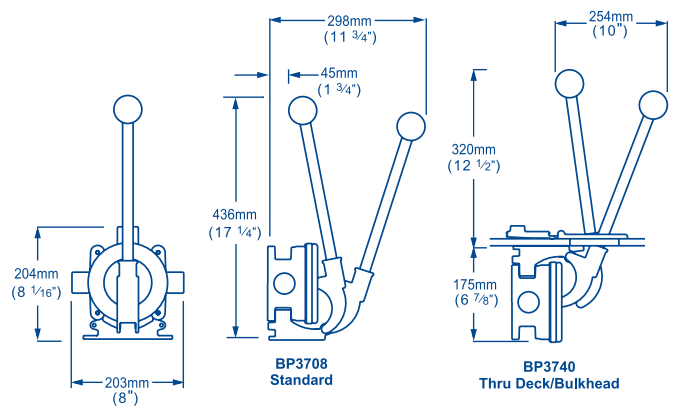

FRONT VIEW

SIDE VIEW

SIDE VIEW

LARGEST CAPACITY MANUAL BILGE PUMP IN THE WHALE RANGE

- ▶ Top Performance 117 ltrs/min (31 US Gals)
- ▶ Reliability - fully enclosed twin diaphragms
- ▶ Efficient operation, double acting pumps on to and fro strokes
- ▶ Pumps oily bilge water with ease
- ▶ Robust design, corrosion resistant powder coated aluminium alloy

Model	Gusher 30		
	On Deck	On Bulkhead	Thru Deck only
PART NUMBER	BP3000	BP3010	BP3020
Weight	5.05kg (11.1lbs)		5.9kg (13lbs)
Hose connection	38mm (1½")		
Materials	Pump Body: Marine Grade LM6 Aluminium Alloy (epoxy coated), Diaphragm: Neoprene, Bushes: Acetal, Handwheels: Nylon, Fasteners: Stainless Steel		
Materials in contact with fluid	Marine Grade LM6 Aluminium Alloy (Epoxy Coated), Nitrile®, Stainless Steel		
Service kits	AK3051 - Service Kit for Gusher® 30, Contains: Diaphragms, Valves, Gasket, AS3725 - Gaiter Kit - for use with BP3020, AS3016 - Handwheel / stud kit, AS3015 - Lever Assembly		
Accessories	AS3095 - Spare Handle, DP3804 - Deckplate, AS3020 - Deckplate Conversion Kit		

	Performance		
PART NUMBER	BP3000 / BP3010 / BP3020		
Maximum suction lift	4m (13ft)		
Maximum discharge head	4m (13ft)		
Suction lift	0m (0ft)	1m (3ft)	2m (6ft)
Discharge head	0.5m (1.5ft)	0.5m (1.5ft)	0.5m (1.5ft)
40 Strokes per minute	75 ltrs/min (20 US Gals)	71 ltrs/min (19 US Gals)	71 ltrs/min (19 US Gals)
70 Strokes per minute	117 ltrs/min (31 US Gals)	111 ltrs/min (29 US Gals)	111 ltrs/min (29 US Gals)

For further guidance on the selection of the correct pump, please see page 119

WARRANTY 5 YEARS

- ▶ Suitable as a primary bilge pump on boats equal to or greater than 12m (40ft) in accordance with ISO 15083
- ▶ Approved by Lloyds (MCA)
- ▶ ISO 18813



**THRU DECK
BP3020**

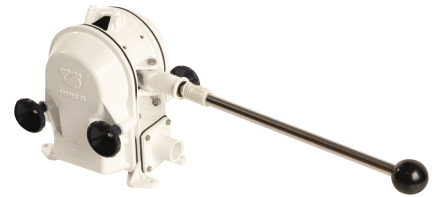

**ON BULKHEAD
BP3010**

MANUAL BILGE

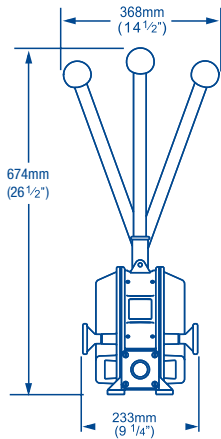

**BP3000
SIDE VIEW**

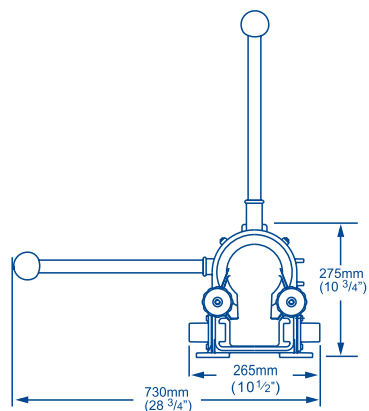

**BP3010
FRONT VIEW**

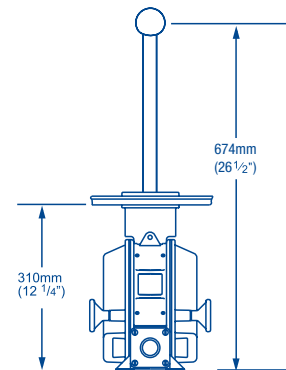

**BP3020
SIDE VIEW**

COMPACT BILGE AND WASTEWATER TRANSFER PUMP

- ▶ Top performance 55 ltrs/min (14.5 US Gals)
- ▶ Multiple mounting options
- ▶ Compact design, ideal for confined spaces
- ▶ Clamp ring easily removed for pump head rotation and quick maintenance
- ▶ Versatility of design - dual size ports

Model	Gusher Urchin		
	On Deck - Fixed handle	Thru Deck / Bulkhead	On Deck - Removable handle
PART NUMBER	BP9005	BP9013	BP9021
Weight	0.6kg (1.3lbs)	0.96kg (2.0lbs)	0.7kg (1.5lbs)
Hose connection	25mm (1") or 38mm (1½")		
Materials	Pump Body: Glass-filled Polypropylene, Clamp Ring: Acetal, Diaphragm: Neoprene, (Nitrile® option available), Operating Lever BP9005: Glass-filled Nylon, Handle (BP9021 and BP9013 only), Springs, Fasteners: Stainless Steel		
Materials in contact with fluid	Glass-filled Polypropylene, Nitrile, Neoprene, Stainless Steel		
Service kits	AK9003 - Neoprene Parts, AK9011 - Nitrile Parts for Oil and Diesel, Contains: Diaphragms, Valves and Circlips, AS9061 - Whale Gusher Urchin Fork Assembly Under deck + Rh, AS9062 - Whale Gusher Urchin Clamp Ring Kit Std + Rh, AS9066 - Whale Gusher Urchin Clamp Plate Kit, AS9064 - Whale Gusher Urchin Thru Deck or Bulkhead Service Kit		
Accessories	DP8904 - Deckplate Kit (for BP9013 and BP9021 only), AS9060 - Std Operating Lever Kit, AS8680 - Spare Handle (for BP9013 and BP9021 only)		

	Performance			
	BP9005 / BP9013 / BP9021			
PART NUMBER				
Maximum suction lift	4m (13ft)			
Maximum discharge head	3m (10ft)			
Hose size	25mm (1")	38mm (1½")	25mm (1")	38mm (1½")
Suction lift	1m (3ft)	1m (3ft)	2m (6ft)	2m (6ft)
Discharge head	0.5m (1.5ft)	0.5m (1.5ft)	0.5m (1.5ft)	0.5m (1.5ft)
45 Strokes per minute	25 ltrs/min (7 US Gals)	37.5 ltrs/min (9.9 US Gals)	25 ltrs/min (7 US Gals)	36 ltrs/min (9.5 US Gals)
70 Strokes per minute	43 ltrs/min (11.4 US Gals)	55 ltrs/min (14.5 US Gals)	40 ltrs/min (10.6 US Gals)	53 ltrs/min (14 US Gals)

For further guidance on the selection of the correct pump, please see page 119

WARRANTY 5 YEARS

- ▶ 25mm (1") Hose connection - Suitable as a primary bilge pump on boats up to 12m (40ft) in accordance with ISO 15083
- ▶ 38mm (1½") Hose connection - Suitable as a primary bilge pump on boats equal to or greater than 12m (40ft) in accordance with ISO 15083



ON DECK REMOVABLE HANDLE
BP9021

THRU DECK OR BULKHEAD
BP9013

ON DECK FIXED HANDLE
BP9005

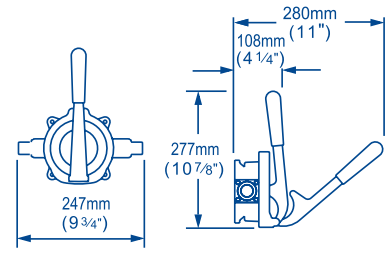

On Deck/Fixed Handle
BP9005

PLAN VIEW

SIDE VIEW

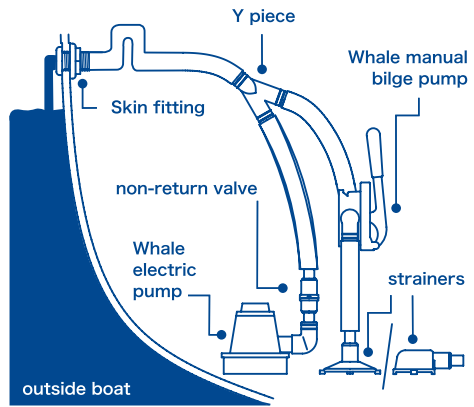

TYPICAL INSTALLATION

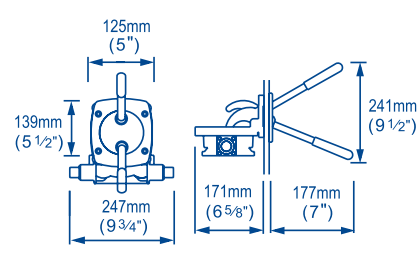

Thru Deck/Bulkhead
BP9013

PLAN VIEW

SIDE VIEW

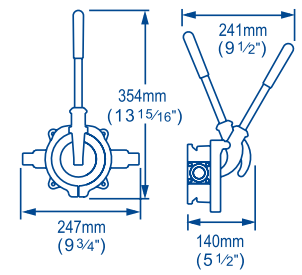

Bulkhead/Removable Handle
BP9021

PLAN VIEW

SIDE VIEW

TOUGH AND LIGHTWEIGHT POLYPROPYLENE MODELS, COMBINES POWERFUL PERFORMANCE AND LIGHTWEIGHT DESIGN

- ▶ High flow rate 105 ltrs/min (28 US Gals)
- ▶ Quick maintenance - clamping ring is easily removed for pump head rotation
- ▶ Multiple mounting options
- ▶ Suitable as primary pump for boats 12m (40ft) and greater
- ▶ Simple plumbing

Model	Gusher Titan	
	On Deck	Thru Deck / Bulkhead
PART NUMBER	BP4402	BP4410
Weight	1.5kg (3.3lbs)	1.85kg (4.1lbs)
Hose connection	38mm (1½")	
Materials	Pump Body: Glass-Filled Polypropylene, Clamp Ring: Acetal, Diaphragm and Valves: Neoprene, (Nitrile® option available), Operating Lever: Glass-filled Nylon, Gaiter: EPDM, Fasteners: Stainless Steel	
Materials in contact with fluid	Glass-Filled Polypropylene, Acetal, Neoprene, Nitrile®	
Service kits	AK4400 - Whale Gusher Titan Neoprene parts (for on deck installations) Diaphragm, Valves and Fixings, AK4419 - Whale Gusher Titan Nitrile® (for oil and diesel, and on deck installations) Diaphragm, Valves and Fixings, AS4406 - Whale Gusher Titan Standard Lever Kit, AS4407 - Whale Gusher Titan Standard Clamping Ring Kit, AS4408 - Whale Gusher Titan Operating Lever U/Deck, AS4409 - Whale Gusher Titan U/Deck Clamping Ring Kit, AS4412 - Whale Gusher Titan Clamping Plate Kit, AS3725 Gaiter Kit For Deckplates (for U/Deck Models - Gusher 30 and 10, Titan, Urchin, MK5)	
Accessories	DP8904 - Deckplate Kit (for BP4410 only), AS4405 - Spare Handle	

	Performance	
PART NUMBER	BP4402 / BP4410	
Maximum suction lift	4m (13ft)	
Maximum discharge head	4m (13ft)	
Suction lift	1m (3ft)	2m (6ft)
Discharge head	0.5m (1.5ft)	0.5m (1.5ft)
45 Strokes per minute	67 ltrs/min (18 US Gals)	65 ltrs/min (16 US Gals)
70 Strokes per minute	105 ltrs/min (28 US Gals)	98 ltrs/min (26 US Gals)

For further guidance on the selection of the correct pump, please see page 119

WARRANTY 5 YEARS

- ▶ Suitable as a primary bilge pump on boats equal to or greater than 12m (40ft) in accordance with ISO 15083



ON DECK
BP4402

Skin fitting 38mm (1 1/2")SF5425

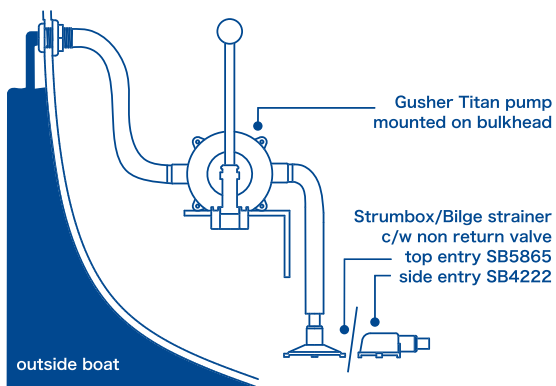

TYPICAL INSTALLATION

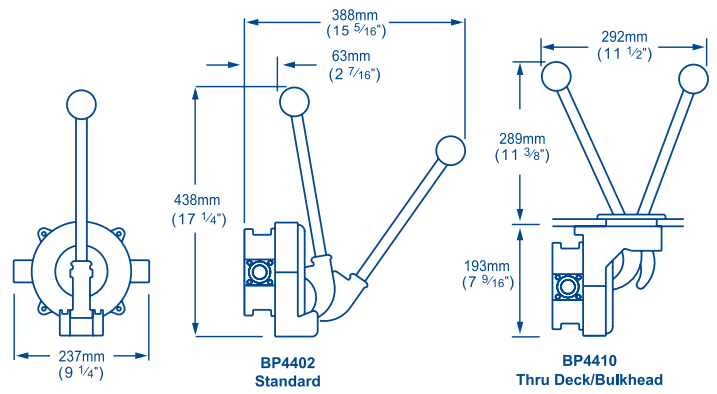

PLAN VIEW

SIDE VIEW

TOUGH, RELIABLE DESIGN AVAILABLE WITH SINGLE OR DOUBLE ACTING CAPABILITIES

MK5 UNIVERSAL

- ▶ Top performance 66 ltrs/min (17 US Gals)
- ▶ Whale's most versatile high-performance pump design
- ▶ Multiple mounting options
- ▶ Suitable as primary pump for boats 12m (40ft) and greater

MK5 DOUBLE ACTING PUMP

- ▶ High output - 104 ltrs/min (27 US Gals)
- ▶ Twin diaphragms - empty 2 bilge compartments at the same time
- ▶ Easy maintenance inspection port
- ▶ Will continue to function even if one diaphragm fails

Model	MK5 Universal	MK5 Double Acting		
	Thru Deck / On Bulkhead / On Deck	On Bulkhead	Thru Deck	On Deck
PART NUMBER	BP0510	MH5550	MH5560	MH5570
Weight	1.3kg (3.0lbs)	2.8kg (6.0lbs)		
Hose connection	38mm (1½")			
Materials	Pump Body: Glass-Filled Polypropylene, Acetal, Diaphragm, Valves and Seals: Nitrile, Operating Lever: Acetal, Glass-filled Nylon, PVC, Handle, Spring and Fasteners: Stainless Steel			
Materials in connection with fluid	Glass-filled Polypropylene, Acetal, Nitrile, Stainless Steel			
Service kits	AK8050 - Service Kit for MK5 Contains: Diaphragms, Valves and Circlips, AS0511 - Spare Handle, AS0521 - Rocker Arm Assembly, AS0522 - Front Cover / Body Assembly, AS0531 - Under Deck Rocker Arm Assembly	AK8060 - Service Kit for MK5 D Acting - contains: Diaphragms, Valves and Circlips, AS8551 - Rocker Arm Assembly, AS8552 - Clamping Plate and Nut Kit		
Accessories	AS3725 - Gaiter Kit, DP9906 - Deckplate Kit (includes cover)			

	Performance	
PART NUMBER	BP0510	MH5550 / MH5560 / MH5570
Maximum suction lift	4.5m (14.8ft)	
Maximum discharge head	4.5m (14.8ft)	
Suction lift	1m (3ft)	
Discharge head	0.5m (1.5ft)	
45 Strokes per minute	42 ltrs/min (11 US Gals)	64 ltrs/min (17 US Gals)
70 Strokes per minute	66 ltrs/min (17 US Gals)	104 ltrs/min (27 US Gals)

For further guidance on the selection of the correct pump, please see page 119

WARRANTY 5 YEARS

- ▶ Suitable as a primary bilge pump on boats equal to or greater than 12m (40ft) in accordance with ISO 15083
- ▶ Approved by Lloyds (MCA)
- ▶ USCG Approved - MK5 Universal Size 2, MK5 Double Acting Size 3



MK5 DOUBLE ACTING MANUAL BILGE PUMP

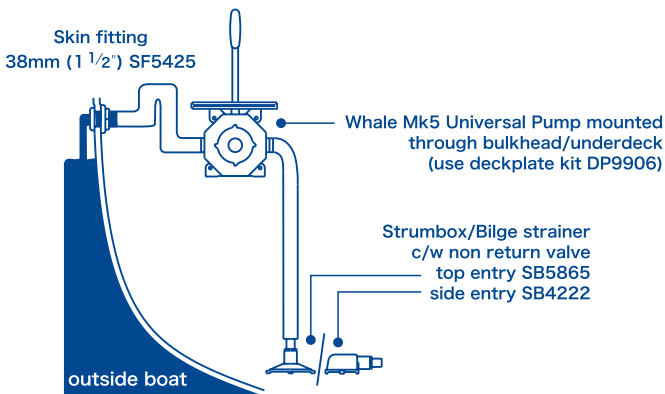
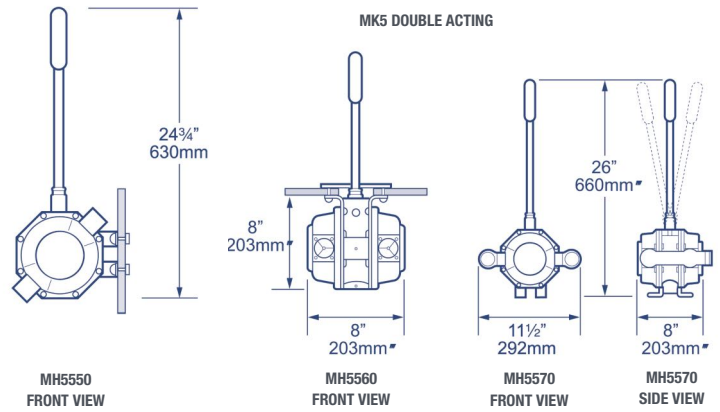

TYPICAL INSTALLATION

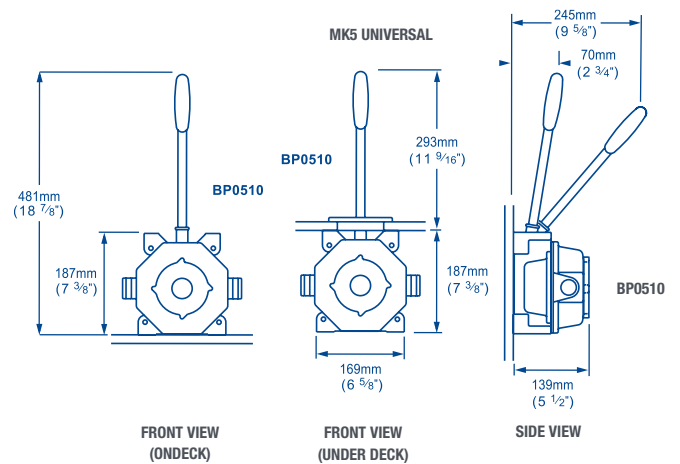

DESIGNED FOR CONFINED SPACES WHERE SPACE IS LIMITED

- ▶ Top performance 35 ltrs/min (9.2 US Gals)
- ▶ Easy maintenance - easy to remove clamp ring for maintenance/head rotation
- ▶ Tough, proven, reliable, slimline design
- ▶ Suitable for pumping bilge saltwater or diesel
- ▶ Includes sleek Whale deckplate with cover

Model	Compac 50
	Thru Deck / Bulkhead
PART NUMBER	BP0350
Weight	0.9kg (2.0lbs)
Hose connection	25mm (1")
Materials	Pump Body: Glass-filled Polypropylene, Clamp Ring: Acetal, Diaphragm, Valves and Seals: Nitrile, Operating Lever: Glass-filled Nylon, Gaiter: EPDM, Deck Plate Cover: PBT, Fasteners: Stainless Steel
Materials in contact with fluid	Glass-filled Polypropylene, Nitrile, Stainless Steel
Service kits	AK8035 - Whale Compac 50 Diaphragm, Valves and Fixings, AS0352 - Whale Compac 50 Rocker Arm + Clamp Plate Kit, AS0353 - Whale Compac 50 Clamping Ring Kit, AS0355 - Whale Compac 50 Handle Assembly
Accessories	AS0355 - Spare Handle, AS0356 - Deckplate Kit

	Performance
PART NUMBER	BP0350
Maximum suction lift	3m (10ft)
Maximum discharge head	4m (13ft)
Suction lift	1m (3ft)
Discharge head	0.5m (1.5ft)
45 Strokes per minute	32 ltrs/min (9 US Gals)
70 Strokes per minute	35 ltrs/min (9.2 US Gals)

For further guidance on the selection of the correct pump, please see page 119

WARRANTY 5 YEARS

- ▶ Suitable as a primary bilge pump on boats equal to or greater than 12m (40ft) in accordance with ISO 15083

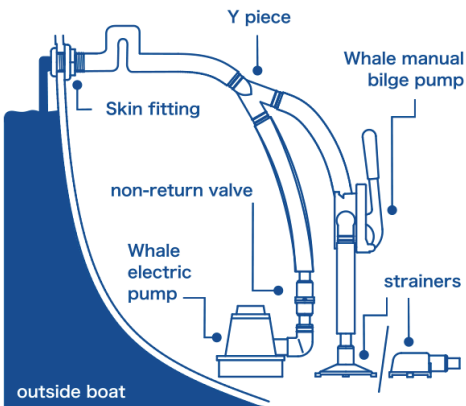

TYPICAL INSTALLATION

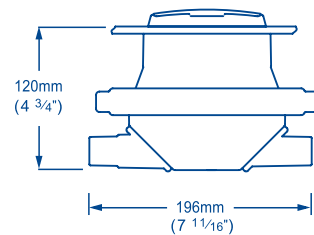

FRONT VIEW

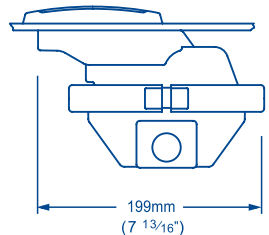

SIDE VIEW

WHALE'S LOW-PROFILE COMPACT PUMP DESIGNED FOR CONFINED SPACES

- ▶ Top performance 67.7 ltrs/min (17.9 US Gals)
- ▶ Compact size is ideal where space is limited
- ▶ Easy pump action
- ▶ Ease of installation - self-sealing design means no need for messy sealants

Model	Smartbail
	Thru Bulkhead
PART NUMBER	BP5012
Weight	0.6kg (1.31lbs)
Hose connection	2 options included: 25mm ports (1") qty 2, 38mm ports (1½") qty 2
Materials	Pump Body: Glass-Filled Polypropylene, Inlet and Outlet Valves: Nitrile, Diaphragm: Santoprene®, Fastners: Stainless Steel
Materials in contact with fluid	Glass-filled Polypropylene, Stainless Steel, Nitrile, Santoprene®
Service kits	AK5010 - Diaphragm, Valves and Seals

		Performance			
PART NUMBER		BP5012			
Maximum suction lift		3m (9.8ft)			
Maximum discharge head		3m (9.8ft)			
Maximum combined head and lift		3m (9.8ft)			
		BP5012 (with 25mm ports)		BP5012 (with 38mm ports)	
Port size		25mm (1") ports		38mm (1 ½") ports	
Lift	Head	45 Strokes/min	70 Strokes/min	45 Strokes/min	70 Strokes/min
0m (0ft)	0m (0ft)	32.75 ltrs/min (8.7 US Gals)	51 ltrs/min (13.5 US Gals)	43.5 ltrs/min (11.5 US Gals)	67.7 ltrs/min (17.9 US Gals)

For further guidance on the selection of the correct pump, please see page 119

WARRANTY 5 YEARS

- ▶ Suitable as a primary bilge pump on boats equal to or greater than 12m (40ft) accordance with ISO 15083

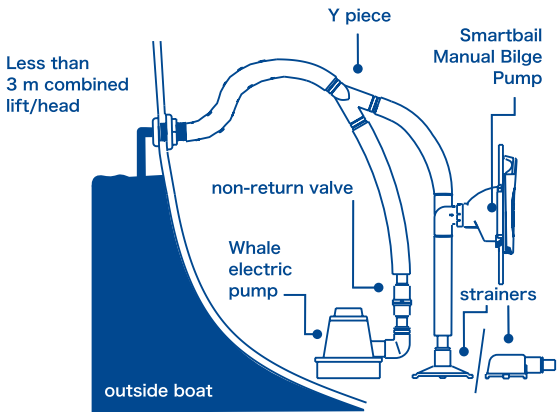

TYPICAL INSTALLATION

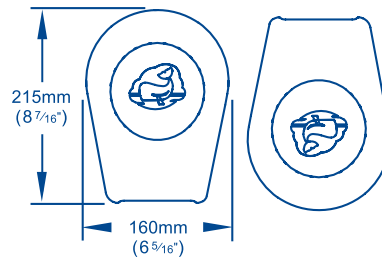

FRONT VIEW

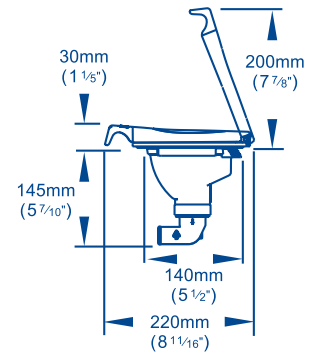

SIDE VIEW

THE PORTABLE CHOICE INSTANTLY READY FOR USE

- ▶ Portable lightweight design
- ▶ Suitable for bilge water or diesel transfer
- ▶ Flexible hose can easily be directed to hard to reach bilge areas
- ▶ Available in 2 barrel lengths
- ▶ Ideal for small boats, dinghies and kayaks

Model	Easybailer	
	Short barrel version	Long barrel version
PART NUMBER	BP1935	BP1955
Weight	0.32kg (0.7lbs)	0.4kg (0.9lbs)
Hose connection	25mm (1")	
Materials	Pump Body: ABS, HDPE, Polypropylene, PVC, uPVC, Diaphragm: Neoprene, Fasteners: Stainless Steel	
Materials in contact with fluid	ABS, HDPE, Polypropylene, PVC, uPVC, Neoprene, Stainless Steel	

	Performance	
	BP1935 / BP1955	
PART NUMBER		
Suction lift	0m (0ft)	1m (3ft)
Discharge head	0.5m (1.5ft)	0.5m (1.5ft)
45 Strokes per minute	19 ltrs/min (5 US Gals)	19 ltrs/min (5 US Gals)
70 Strokes per minute	31.4 ltrs/min (8.3 US Gals)	31.4 ltrs/min (8.3 US Gals)

For further guidance on the selection of the correct pump, please see page 119

WARRANTY 1 YEARS

▶ ISO 15083



MANUAL BILGE

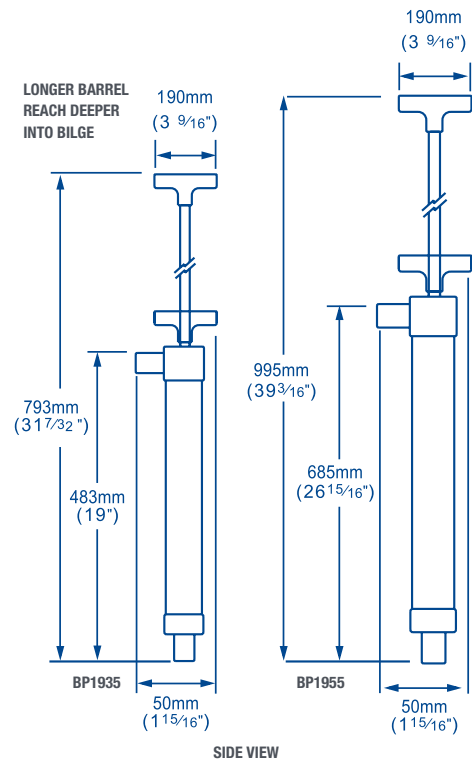

COMPLETE YOUR SYSTEM

Fit Whale high quality pumps and accessories to ensure long term reliability throughout your bilge waste system. Whale switches, diverter valves, and pipework connections are designed and manufactured to the highest quality specification. Combine these accessories with your Whale bilge pumps for reliability and durability.

ELECTRIC FIELD SENSOR RANGE

- ▶ Electric field sensor automatically senses water levels and switches on the bilge pumps
- ▶ Nylon material - withstands high temperatures
- ▶ Automatically switches on when 51mm (2") of water is sensed and turns off when water drops below 13mm (½")
- ▶ BE9006 model - built in 30 second off delay for efficient operation, prevents cycle in small sump installations or enables lower drain than 13mm (½")

SUITABLE FOR ORCA, SUPERSUB, STANDARD SUBMERSIBLE RANGES AND GULPER

	Electric Field Sensor	
Model	Electric Field Sensor Switch	Electric Field Sensor Switch with 30 second time delay
PART NUMBER	BE9003	BE9006
Voltage	12V d.c. or 24V d.c.	
Current	Suitable up to 20 amps	
Standby current	0.008 amp	

WARRANTY 1 YEAR

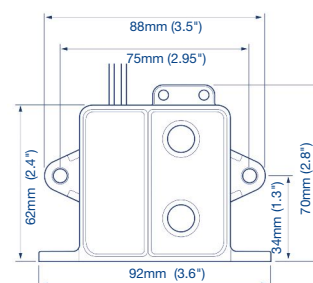

SIDE VIEW

ATTWOOD FLOAT SWITCH

- ▶ Ideal for use with electric bilge pump
- ▶ Float switch senses water levels and switches on the bilge pumps
- ▶ Automatically switches on when 51mm (2") of water is sensed
- ▶ Easy to install, mounted on either horizontal or vertical surface (e.g. bulkhead or hull)
- ▶ Suitable for installations where current draw is up to 12 amps
- ▶ Compact design

SUITABLE FOR ORCA, SUPERSUB, STANDARD SUBMERSIBLE RANGES AND GULPER

	Float Switch
Model	Attwood Float Switch with Cover
PART NUMBER	4201-7
Voltage d.c.	12V d.c. or 24V d.c.
Current	Suitable up to 12 Amps

WARRANTY 1 YEAR

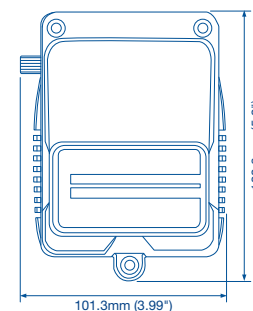

SIDE VIEW

Y PIECE

WARRANTY 1 YEAR

- ▶ Designed to enable two pumps to discharge through a single line
- ▶ Ideal for use when a diverter is not required

Model	Y Piece
PRODUCT NUMBER	YP6114
Pipe diameter	38mm (1½")
Materials	Polypropylene



ELBOWS

- ▶ Ideal for use in installations in confined spaces

Model	Elbows	
PRODUCT NUMBER	EB3364	EB3488
Pipe diameter	25mm (1")	38mm (1½")
Materials	Polypropylene	



NON-RETURN VALVES

- ▶ Extensive range now includes ¾" and 1⅛" models
- ▶ Provide an easy way to maintain prime in a suction or discharge line
- ▶ Designed to fit inline
- ▶ Suitable for use with manual or electric pumps



Model	Non Return Valves		
PRODUCT NUMBER	LV1215	LV1218	LV1219
Pipe diameter	25mm (1") / 38mm (1½")	25mm (1") / 28mm (1⅛")	19mm (¾") / 25mm (1")
Materials	Body: Glass-filled Polypropylene, Glass-filled Nylon, Valve: Nitrile		



Note: These specifications are retail items only. For details of our bulk pack range for boat builders and wholesalers - contact Whale Support.

DIVERTER VALVES

WARRANTY 5 YEARS

- ▶ Allows one pump to draw from 2 locations
- ▶ Robust, reliable design
- ▶ Teflon® lubricated non-stick operation
- ▶ Precision machined for odour-proof seal
- ▶ Withstands sewage/black waste, saltwater and bilge water
- ▶ Models available in either 25mm (1") or 38mm (1½") hose connection

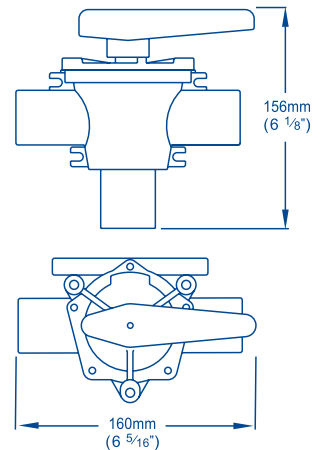
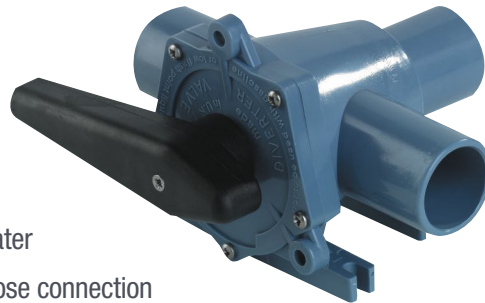

TYPICAL USES

- ▶ Suitable for electric or manual waste management systems
- ▶ Used in bilge and toilet waste systems
- ▶ Diverts flow to holding tank or overboard for deck pump out

Diverter Valve		
PART NUMBER	DV5630	DV5606
Hose connection	25mm (1")	38mm (1½")
Materials	Main Body: Acetal, Teflon®, Handle: PTFE Polyester	

BILGE STRAINERS / STRUM BOXES

¾" (19mm) Strainer with Multi-Directional Port and Non-Return Valve

1" (25mm) / 1½" (38mm) Strainers with Top or Side Entry



Model	Multi-Directional	Top Entry	Side Entry
PART NUMBER	SB3422	SB5865	SB4222
Hose connection	19mm (¾")	25mm (1") / 38mm (1½")	
Materials	Polypropylene, Nitrile, Stainless Steel		

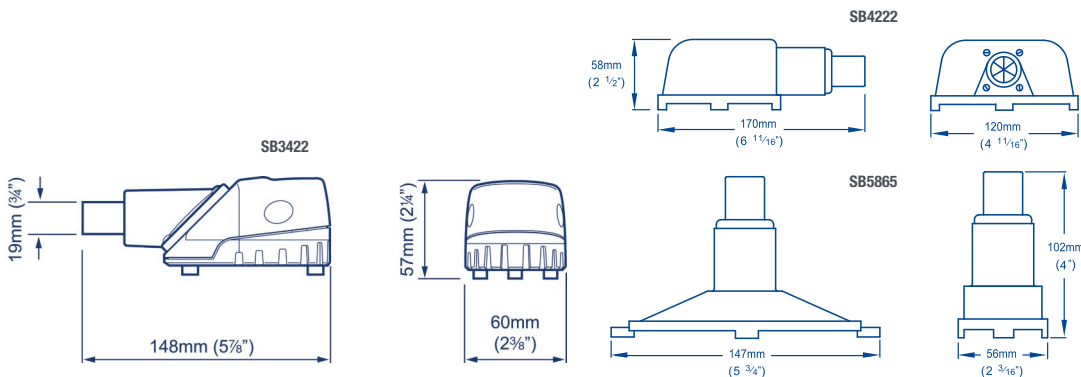

A COMPREHENSIVE RANGE OF BILGE PUMP COVERS

- ▶ Provides a neat cover over manual bilge pumps
- ▶ Aesthetic designs
- ▶ Manufactured from UV stabilised plastic
- ▶ Snap-shut lid remains closed when pump is not in use

Deckplate Selector			
PART NUMBER	Model	Materials	For use with
DP8904	Plastic 4 Hole Model	PBT	Gusher® Urchin, Gusher® Titan, Gusher® 10
DP3804	Metal 4 Hole Model	Cast Aluminum LM6	Gusher® 10, Gusher® 30 (BP3020)
DP9905	Plastic 6 Hole Deck Ring	Acetal	MK5 Underdeck BP0535 / MH5560
DP9906	Plastic 4 Hole Covered Model	PBT	MK5 Universal
AS0356	Plastic 4 Hole Model	PBT	Compac 50
AS3020	Includes DP3804 + Bridge Selection	Cast Aluminum LM6	Gusher® 30 (BP3020)



DP8904



DP3804



DP9905



DP9906



AS0356



AS3020

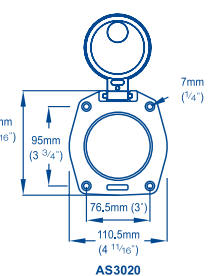
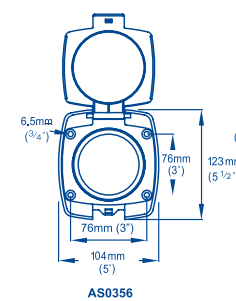
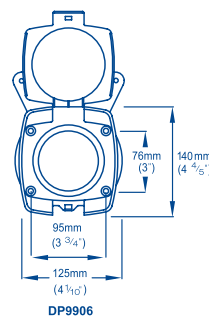
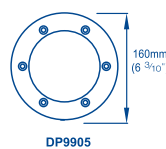
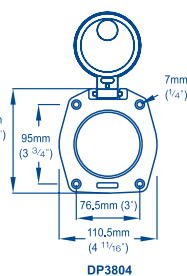
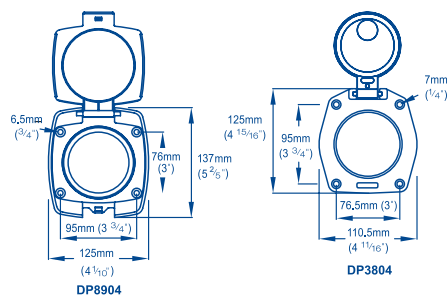

FRESHWATER





THE ONE STOP FOR YOUR COMPLETE FRESHWATER SYSTEM

Whale's wide range of freshwater pumps, plumbing and accessories offer all you need for a smooth and constant freshwater supply on board. Our range includes a variety of manual and electric pumps with various flow rates and pressure settings to best suit your boat. Our extensive range allows you to fit a complete Whale system from plumbing, pumps and filters to faucets and showers.

WATERMASTER® AUTOMATIC PRESSURE PUMP

Delivers smooth consistent flow and runs dry without damage

- ▶ Easy installation - suitable for 15mm Quick Connect plumbing or ½" threaded connection
- ▶ Self-priming up to 3m (10ft)
- ▶ Delivers smooth constant flow
- ▶ Mounting feet rotate to suit your installation
- ▶ IP67 sealed protective motor housing with integrated pressure switch

Model	Watermaster			
PART NUMBER	FW0814	FW1214	FW1215	FW1225
Weight	1.5kg (3.3lbs)			
Voltage	12V d.c.			24V d.c.
Fuse size	5 amps	7.5 amps		5 amps
Cable size	2.5mm ² (14AWG)			
Hose connection	Whale Quick Connect 15mm Female Connections 2 x ½" threaded connections and 2 x ½" barbed connections included			
Materials	Pump Body: Glass-filled Polypropylene, Pump Internal: PBT, Motor Casing: Stainless Steel, Diaphragm, Valves, Feet: Monprene, Seals: Nitrile®, Fasteners: Stainless Steel			
Materials in contact with fluid	Pump Body: Glass-filled Polypropylene, Pump Internal: PBT, Valves: Monprene®, Seals: Nitrile, Fasteners: Stainless Steel			
Service kits	AK1316 - Replacement Head, AK1319 - Replacement Strainer (for freshwater)			

	Performance			
PART NUMBER	FW0814	FW1214	FW1215	FW1225
Maximum system pressure (Cut Out)	2 bar (30 psi)		3 bar (45 psi)	
Open flow rate per minute	8 ltrs (2 US Gals)	11.5 ltrs (3 US Gals)	11.5 ltrs (3 US Gals)	

For further guidance on the selection of the correct pump, please see page 121

WARRANTY 2 YEARS

- ▶ CE Certified
- ▶ ISO 8846
- ▶ ISO 10133
- ▶ ABYC H-23
- ▶ IP67



FILTER AND FITTINGS INCLUDED



1 X STRAINER



2 X 1/2" THREADED CONNECTORS



2 X 1/2" BARBED CONNECTORS

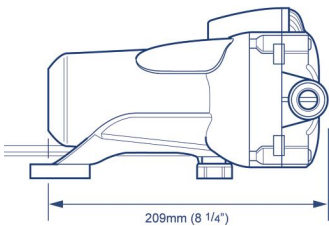

SIDE VIEW

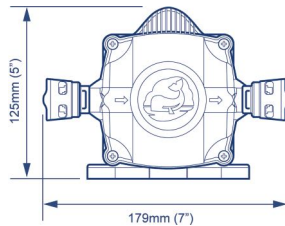

FRONT VIEW

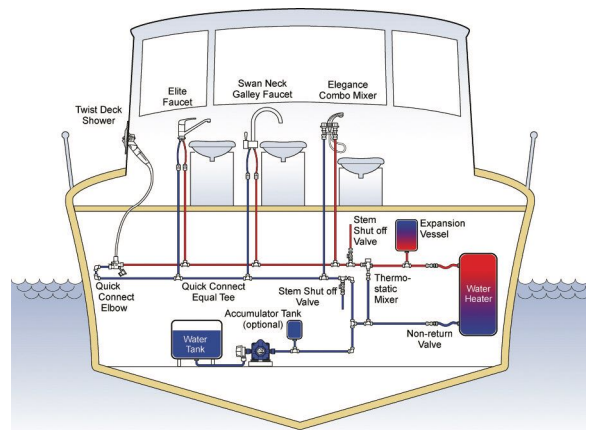

TYPICAL INSTALLATION

FRESHWATER

SUBMERSIBLE AND INLINE IMPELLER RANGE

Whale's high flow long life submersible and inline galley pumps

- ▶ Narrow design ideal to drop into your water tank
- ▶ Compact, quiet, lightweight design suitable for use with pressure switch and microswitch systems
- ▶ Inexpensive way to upgrade your manual water system
- ▶ Also suitable for pumping diesel
- ▶ Low power consumption

Model	Standard		Premium				High flow	
PART NUMBER	GP1002		GP1352	GP1392	GP1354	GP1394	GP1652	GP1692
Pump type	Sub		Sub	Inline	Sub	Inline	Sub	Inline
Weight	0.15kg (0.3lbs)							
Voltage	12V d.c.				24V d.c.		12V d.c.	
Recommended fuse size	5 amps				3 amps		5 amps	
Cable length	1m (3ft)							
Hose connection	Suitable for 10mm (3/8") or 13mm (1/2") Flexible Hose Use WX1511B (Stem Adaptor 11mm-15 mm) Connect WX1504 (15mm (5/8) Equal Straight)							
Materials in contact with fluid	Pump Body: ABS, Seals: Nitrile, Strainer: Polypropylene, Impeller: PBT, Cable: PVC							
Filter included	No		Yes	No	Yes	No	Yes	No

Performance							
PART NUMBER	GP1002	GP1352	GP1392	GP1354	GP1394	GP1652	GP1692
Discharge head	Flow rate per minute/ current draw @12v d.c.	Flow rate per minute/ current draw @12V d. c.		Flow rate per minute/ current draw @24V d. c.		Flow rate per minute/ current draw @12V d.c.	
0m (0ft)	10.3 ltrs (2.7 US Gals) 2.4 amps	13.2 ltrs (3.5 US Gals) 3.6 amps		13.2 ltrs (3.5 US Gals) 1.8 amps		15.8ltrs (4 US Gals) 3.8 amps	
1m (3ft)	8 ltrs (2 US Gals) 2.2 amps	11.75 ltrs (3 US Gals) 3.3 amps		11.75 ltrs (3 US Gals) 1.6 amps		14.8ltrs (4 US Gals) 3.7 amps	
3m (10ft)	5.75 ltrs (1.5 US Gals) 2 amps	9.75 ltrs (2.7 US Gals) 2.9 amps		9.75 ltrs (2.7 US Gals) 1.45 amps		12.8ltrs (3.5 US Gals) 3.5 amps	

For further guidance on the selection of the correct pump, please see page 120

WARRANTY 1 YEAR

- ▶ CE Certified
- ▶ ISO 8846
- ▶ ISO 10133
- ▶ ABYC H-23
- ▶ IP67

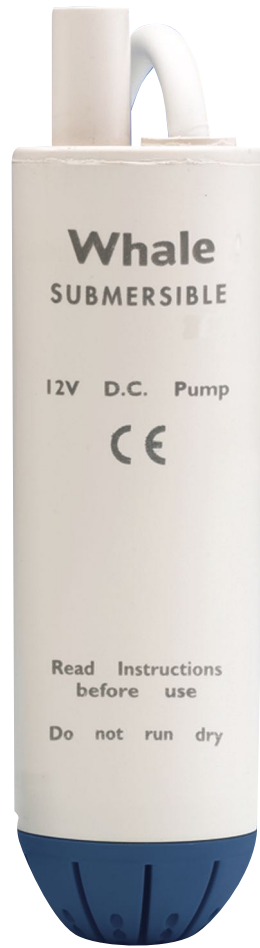

FRESHWATER

	A	B	C	D
Standard	20mm (3/16")	88mm (3 7/16")	36mm (1 7/16")	108mm (4 1/4")
Premium/High Flow	20mm (3/16")	109mm (4 5/16")	36mm (1 7/16")	129mm (5 1/16")

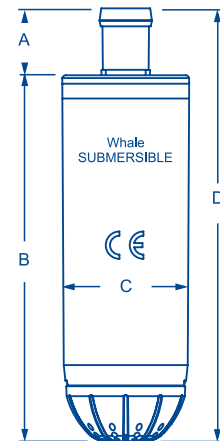

SMOOTH CONSTANT FLOW IN ONE INTEGRATED KIT

Reduces water hammering and cycling

- ▶ Combined pump and accumulator tank ensure a smooth even flow of water to all outlets
- ▶ Compact design installs easily in convenient locations
- ▶ Reduced noise and vibration by preventing pump cycling
- ▶ Easily plumbed into standard ½" or ¾" pipework
- ▶ Can be fitted to new or existing systems
- ▶ Pump available separately

Model	Accumulator Kits					
PART NUMBER	UF2214	UF2215	UF2224	UF2225	UF2015	UF8025
Accumulator tank size	2 ltrs (0.53 US Gals)				8 ltrs (2.1 US Gals)	
Weight	3.9kg (8.5lbs)				5.4kg (11.9lbs)	5.9Kg (13lbs)
Voltage	12V d.c.		24V d.c.		12V d.c.	24V d.c.
Fuse size	10 amps		5 amps		8 amps	8 amps
Cable size	1.5mm ² (16AWG)					
Hose connection	Whale Quick Connect 15mm Female For (½"), Flexible Hose, Use WX1584 (supplied with kit), For ¾" Flexible Hose, Use WU1215 and WU1280 (not supplied with kit)					
Materials	Pump Body: Glass-filled Polypropylene Aluminium and Powder-coated Steel, Diaphragms: Santoprene®, Valves and Feet: Monoprene®, Seals: Nitrile, Tank: Butyl, Base: ABS, Fittings: Brass, Fasteners: Stainless Steel					
Materials in contact with fluid,	Glass-filled Polypropylene, Monprene®, Nitrile, Stainless Steel, Brass, Santoprene®					
Service kits	AK1316 - Replacement Head, AK1317 - Microswitch Kit, AK1319 - Replacement Strainer (for freshwater), PT0200 - Accumulator Tank					

Performance						
PART NUMBER	UF2214	UF2215	UF2224	UF2225	UF2015	UF8025
Maximum suction lift	3m (10ft)					
Maximum discharge head	20m (66ft)	30m (99ft)	20m (66ft)	30m (99ft)	20m (66ft)	30m (99ft)
Maximum system pressure (Cut Out)	2 bar (30 psi)	3 bar (45 psi)	2 bar (30 psi)	3 bar (45 psi)	3 bar (45 psi)	3 bar (45 psi)
Factory pre-charge pressure (+/-0.14 bar +/- 2 psi)	1.5 bar (22 psi)	2.2 bar (32 psi)	1.5 bar (22 psi)	2.2 bar (32 psi)	1.4 bar (20 psi)	2.2 bar (32 psi)
Open flow rate per minute	12 ltrs (3 US Gals)				12 ltrs (3 US Gals)	18 ltrs (5 US Gals)

For further guidance on the selection of the correct pump, please see page 121

WARRANTY 2 YEARS

- ▶ CE Certified
- ▶ ISO 8846
- ▶ ISO 10133
- ▶ ABYC H-23



FRESHWATER

MODELS:
UF2214, UF2215, UF2224, UF2225

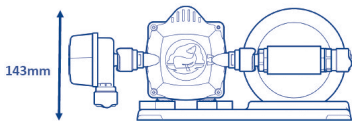

FRONT VIEW

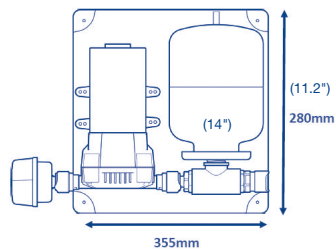

PLAN VIEW



MODELS:
UF2015, UF8025

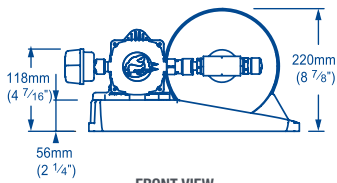

FRONT VIEW

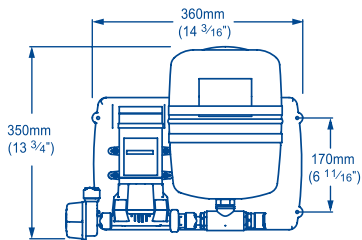

PLAN VIEW

DOUBLE STACK FRESHWATER PUMP SYSTEM

Twin pump design efficiently delivers smooth water flow in vessels with up to 8 outlets

- ▶ Fast installation - pre-assembled system
- ▶ Reduces noise and vibration by preventing pump cycling
- ▶ Small footprint - ideal for installation in tight spaces
- ▶ Unique mounting bracket ensures compact footprint and includes vibration reducing feet
- ▶ Robust industrial grade external pressure switches are ignition protected and require no relays

Model	High Capacity Freshwater Kit			
PART NUMBER	UF2415B	UF2425B	UF3615B	UF3625B
Accumulator tank size	2 ltrs (0.53 US Gals)			
Weight	8.7kg (19lbs)		9.8kg (22lbs)	
Voltage	12V d.c.	24V d.c.	12V d.c.	24V d.c.
Recommended fuse size per pump	10 amps	5 amps	12 amps	8 amps
Hose connection	19mm (¾") barb			
Cable size	2.5mm² (20AWG)			
Materials	Pump Body: Glass-filled Polypropylene Aluminium and Powder-coated Steel Diaphragms: Santoprene®, Valves and Feet: Monoprene®, Seals: Nitrile®			
Materials in contact with fluid	Glass-filled Polypropylene, Monprene®, Nitrile®, Stainless Steel, Brass, Santoprene®			
Service kits	AK1314 - Low Pressure Switch, AK1315 - High Pressure Switch, AK2415 - 12L 12V Pump, AK2425 - 12L 24V Pump, AK3615 - 18L 12V Pump, AK3625 - 18L 24V Pump, PT0200 - Accumulator Tank			

Model	Performance			
PART NUMBER	UF2415B	UF2425B	UF3615B	UF3625B
Maximum suction lift	20m (66ft)	30m (99ft)	20m (66ft)	30m (99ft)
Maximum discharge head	3m (10ft)			
Cut out pressure	Pump 1: 3 bar (45 psi) Pump 2: 2 bar (30 psi)			
Cut in pressure	Pump 1: 2 bar (30 psi) Pump 2: 1.4 bar (20 psi)			
Factory pre-charge pressure	2.2 bar (32 psi)			
Open flow rate per minute	24 ltrs (6.3 US Gals)		32 ltrs (8.4 US Gals)	
No. of outlets	Up to 6		Up to 8	

For further guidance on the selection of the correct pump, please see page 121

WARRANTY 2 YEARS

- ▶ CE Certified
- ▶ ISO 8846
- ▶ ISO 10133
- ▶ ABYC H-23



FRESHWATER

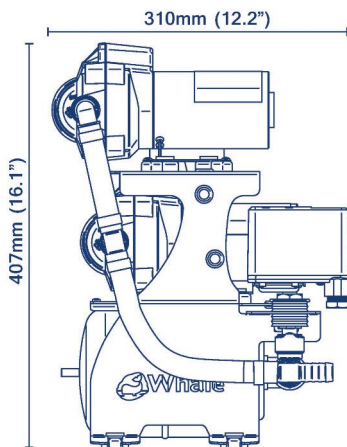

SIDE VIEW

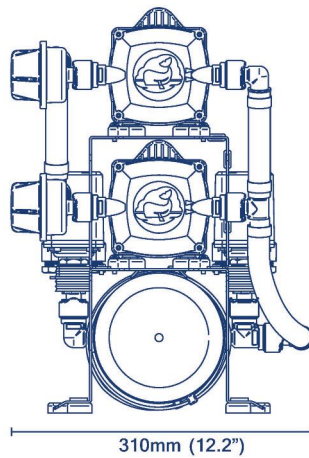

FRONT VIEW

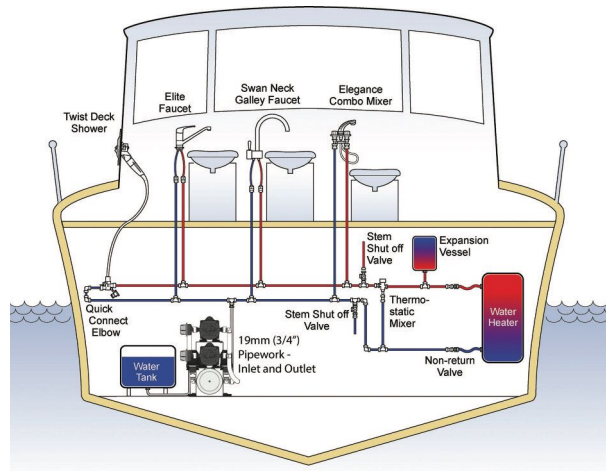

TYPICAL INSTALLATION

SIMPLE HAND OPERATED SOLUTION FOR PUMPING WATER IN THE GALLEY

Narrow mounting base allows installation for use between two sinks

- ▶ Ideal where space is limited
- ▶ Angled spout and adjustable height provide various options for installation
- ▶ Useful as a back-up pump or for a simple freshwater supply
- ▶ Suitable for freshwater and saltwater
- ▶ Extended spout makes for easy filling of containers

Model	V Pump MK7
PART NUMBER	GP0650
Weight	0.26kg (0.6lbs)
Hose connection	Suitable for Quick Connect 15mm plumbing or 13mm (½") Flexible hose
Materials	Pump Body: Acetal, Pump Barrel: Anodized Aluminium Alloy Seals: Neoprene, Nitrile, Fasteners: Stainless Steel
Service kits	AK0618 - Service Kit for V Pump, MK5, MK6 and MK7 Models Contains: Diaphragm, Seals, Fastener

	Performance
PART NUMBER	GP0650
Maximum suction lift	3m (10ft)
Maximum discharge head	4m (13ft)
Maximum flow rate per minute	8 ltrs (2.2 US Gals)

For further guidance on the selection of the correct pump, please see page 120

WARRANTY 5 YEARS

- ▶ CE Certified

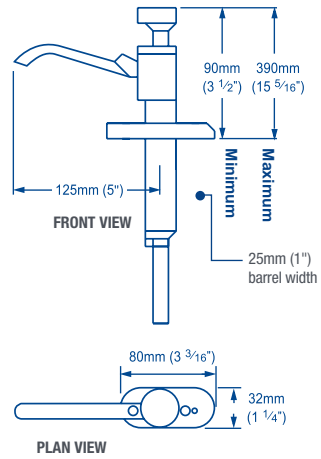

FRESHWATER

SIMPLE HAND OPERATED SOLUTION FOR PUMPING WATER IN THE GALLEY

- ▶ Swivelling outlet - ideal for installing between two sinks
- ▶ Precise flow control
- ▶ Easy operation - light back and forth pump action
- ▶ Suitable for fresh and saltwater

Flipper Pump MK4	
PART NUMBER	GP0418
Weight	0.26kg (0.6lbs)
Hose connection	Suitable for 13mm (½") Flexible hose
Materials	Pump Body: Acetal, Nylon, Polypropylene LM6 Aluminium Alloy, Stainless Steel, ABS, Brass, Seals: Neoprene, Nitrile, Fasteners: Stainless Steel
Service kits	AK0405 - Service Kit for Flipper Mk3 and Mk4 Models Contains: Diaphragm, Seals, Screws, AS0406 - Flipper Overhaul Kit

Performance	
PART NUMBER	GP0418
Maximum suction lift	3m (10ft)
Maximum discharge head	3m (10ft)
Maximum flow rate per minute	7 ltrs (1.9 US Gals)

For further guidance on the selection of the correct pump, please see page 120

WARRANTY 5 YEARS

- ▶ CE Certified



FRESHWATER

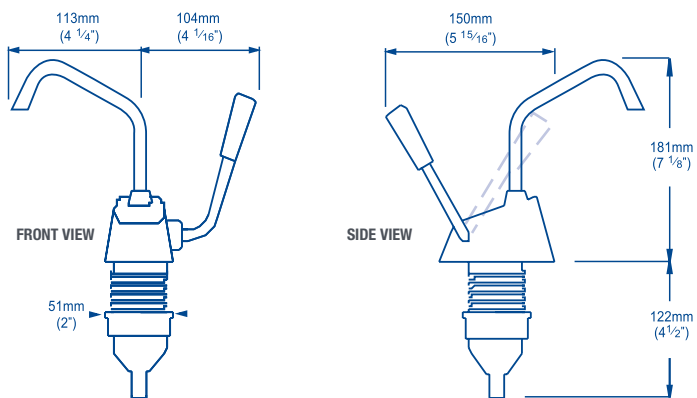

SIMPLE FOOT OPERATED SOLUTION FOR PUMPING WATER IN THE GALLEY

Whale manual self priming galley foot pump

- ▶ Self primes and operates dry without damage
- ▶ Easy, smooth hands-free operation. Left and right oriented foot lever versions available
- ▶ Ease of installation - multi-directional inlet and outlet hose connections
- ▶ 3 mounting options
- ▶ Suitable for fresh and saltwater
- ▶ Ideal as a priming pump for use with Whale inline impeller electric pumps (see page 46)

	Gusher Galley MK3	
PART NUMBER	GP0550	GP0551
Lever mounting	Right	Left
Weight	0.7kg (1.5lbs)	
Hose connection	Suitable for Connection to Whale Quick Connect 15mm Plumbing or 13mm (½") Flexible hose	
Materials	Pump Body: Acetal, Nylon. Lever: LM6 Aluminium Alloy Diaphragm: Nitrile, Neoprene, Fasteners: Stainless Steel	
Service kits	AK0553 - Service Kit for Gusher® Galley (suitable for MK3 only) Contains: Diaphragm, Valves and Seals AS0556 - Piston and Operating Kit	

	Performance
PART NUMBER	GP0550 / GP0551
Maximum suction lift	2m (6ft)
Maximum discharge head	3m (10ft)
Maximum flow rate per minute	15 ltrs (4 US Gals)

For further guidance on the selection of the correct pump, please see page 120

WARRANTY 5 YEARS

▶ CE Certified



FRESHWATER

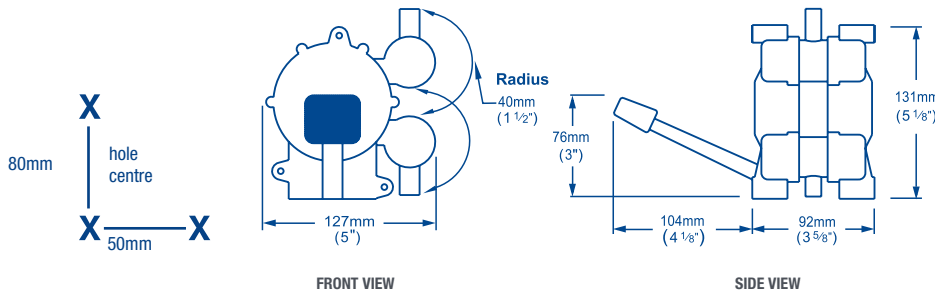
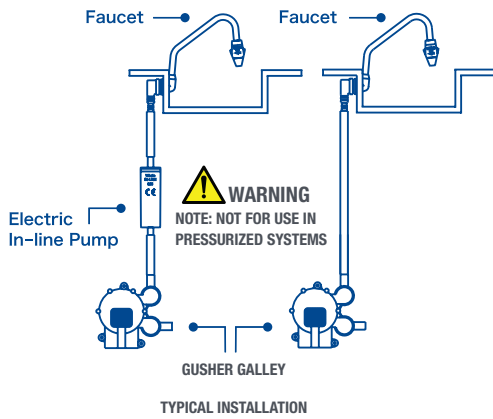

SIMPLE FOOT OPERATED SOLUTION FOR PUMPING WATER IN THE GALLEY

- ▶ Smooth and easy operation
- ▶ Compact for installing in confined spaces
- ▶ Ideal as a priming pump for use with Whale inline impeller electric pumps (see page 46)
- ▶ The ideal foot pump for a simple freshwater system

	Babyfoot
PART NUMBER	GP4618
Weight	0.3kg (0.7lbs)
Hose connection	Suitable for 13mm (½") Flexible Hose
Materials	Pump Body: Nylon, Ports: Acetal, Seals: Neoprene Fasteners: Stainless Steel, Phosphor Bronze
Service kits	AK4615 - Service Kit for Babyfoot® Pump Contains: Diaphragm Valves, O Rings, Spring, Fasteners

	Performance
PART NUMBER	GP4618
Maximum suction lift	1.5m (5ft)
Maximum discharge head	3m (10ft)
Maximum flow rate per minute	8 ltrs (2.2 US Gals)

For further guidance on the selection of the correct pump, please see page 120

WARRANTY 5 YEARS

- ▶ CE Certified



FRESHWATER

 **WARNING**
NOTE: NOT FOR USE IN
PRESSURIZED SYSTEMS

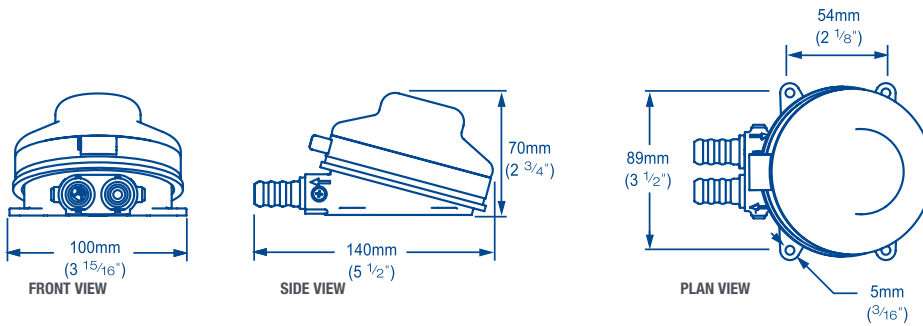

WATER HEATERS





FOR ALL YOUR WARM WATER NEEDS ONBOARD

As an expert in water systems, Whale is proud to offer a complete line of water heaters suited for the harsh marine environment. Available in several capacities and material finishes for any installation, we have the right water heater for your boat.

12V DC WATER HEATER

HOT WATER ON THE GO FOR OUTBOARD BOATS

WARRANTY 2 YEARS

Whale's unique 12V DC Water Heater (3 US Gals) is ideal for use on outboard boats, delivering fast water heat up and long heat retention for all your hot water needs on board

12V DC Power Supply

- ▶ No generator / inverter / shore power required
- ▶ Rapid heat up - hot water in less than 1 hour*
- ▶ Ideal for use with deck showers - perfect for warming wetsuits
- ▶ Safety features - low current switching, integrated temperature and pressure valve, thermal cut-out, heating indication output and ignition protect (ABYC E-11)
- ▶ Compact design - fits in small places



Model	12V DC Electric Water Heater
PART NUMBER	S360EW
Capacity	12 ltrs (3 US Gals)
Weight	11lbs (5kg)
Voltage	12V d.c. (300W)
Fuse size	35 amps
Current draw	30 amps
Connections	½" NPT Female For connection to 15mm Quick Connect use WX1514
Materials	Tank - Aluminium, Casing - White Powder Coated Aluminium
Service kits	SK15360EW Element, SK25360EW Thermostat & Relay SK35360EW Anode, SK45360EW Pressure Valve

*Based on Whale in-house laboratory testing

	Performance
Maximum water temperature	140°F (60°C)
Temperature & pressure valve specifications	210°F (99°C), 75 psi (5.2 bar)
Maximum tested pressure	300 psi (20.7 bar)*

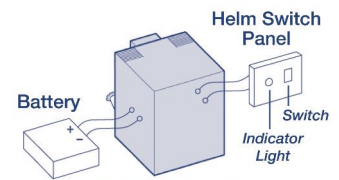

12V Water Heater
SIMPLIFIED INSTALLATION

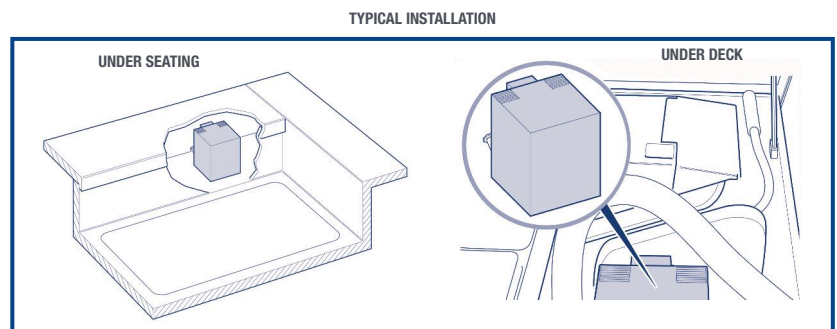
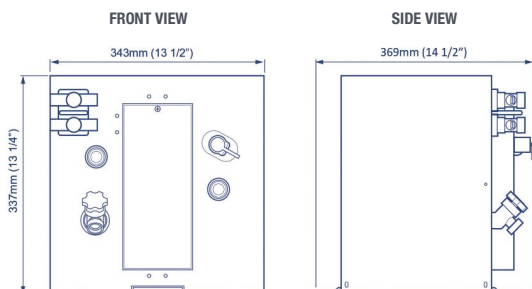

COMBINATION ELECTRIC / HEAT EXCHANGER OR ELECTRIC ONLY MODELS

WARRANTY 2 YEARS

Note All models are available in The Americas only.

- ▶ Robust manufacturing - hold down brackets welded to inner tank
- ▶ Double wall heat exchangers - prevents accidental contamination of freshwater supply
- ▶ Safety controls - integrated pressure relief valve and temperature monitor
- ▶ Sturdy, robust exteriors - produced from marine grade stainless steel, galvanised or epoxy coated
- ▶ Ignition protected



S300EW



WHITE EPOXY COATED
HORIZONTAL WITH SIDE HEAT
EXCHANGER MODEL



WHITE EPOXY COATED
HORIZONTAL ELECTRIC
ONLY MODEL



MARINE GALVANISED STEEL
HORIZONTAL REAR HEAT
EXCHANGER MODEL



STAINLESS STEEL
FRONT HEAT
EXCHANGER MODEL

S300W - 1250W element and requires a 15A Circuit Breaker

S300W - 1250W element and requires a 15A Circuit Breaker

3000 and 4500 models have a 3000W and 4000W element respectively and requires a 15A Dual Breaker (3000) or 20A Dual Breaker (4500)

All other models have a 1500W element and require a 15A Circuit Breaker (120V) or 10A Dual Breaker (240V)

Note: All Whale Water Heaters must be installed and serviced by a qualified electrician in accordance with the Whale appliance installation and operating instructions and appropriate electrical regulations and certifications.

94003-1

THERMOSTATIC MIXING VALVE KIT 95 – 150°F

The Whale Thermostatic Mixing Valve Kit (TMV) is designed for use with Whale Heat marine water heaters that must adhere to ABYC and NMMA regulations for hot water use in leisure craft. These standards state the water must be controlled to 125°F or less. The TMV kit will control the water temperature to the outlet as required.

	Performance
PART NUMBER	94003-1
Suitable fluids	Water
Setting range	35 – 65°C (95 – 150°F)
Tolerance	+ 2°C (+3°F)
Max. working pressure static	150 psi (10 bar)
Max. working pressure dynamic	75 psi (5 bar)
Max. hot water inlet temperature	90°C (195°F)
Max. Inlet pressure ratio (hot/cold, cold/hot)	2:1
Min. temperature difference (hot/mix) for optimal performance	10°C (18°F)
Min. flow rate per minute	2 ltrs (0.5 US Gals)
Max. flow rate per minute	34 ltrs (9 US Gals)
Water connections	Cold water IN and Mixed water OUT, 15mm Whale Quick Connect
Certifications	ASSE 1017/CSA B125.3, NSF/ANSICAN 372



Available in The Americas only

Model		Capacity	Orientation	Heat Exchanger	PSI Rating	Overall Dimensions	Exterior Material	Weights (lbs)
120V	240V					Inches (WxDxH)		
S300W		11 ltrs (3 US Gals)	Horizontal	Side	100 psi	14.5"x14"x13"	White Epoxy	14
S300EW		11 ltrs (3 US Gals)	Horizontal	Electric	100 psi	14.5"x14"x13"	White Epoxy	14
F600	F650	23 ltrs (6 US Gals)	Horizontal	Front	100 psi	13"x19"x13"	Marine Galvanised Steel	26
F600W	F650W	23 ltrs (6 US Gals)	Horizontal	Front	100 psi	13"x19"x13"	White Epoxy	26
	F650WSR	23 ltrs (6 US Gals)	Horizontal	Front	75 psi	13"x19"x13"	White Epoxy	26
F700	F750	23 ltrs (6 US Gals)	Horizontal	Front	100 psi	13"x19"x13"	Stainless Steel	24
S600	S650	23 ltrs (6 US Gals)	Horizontal	Rear	100 psi	13"x19"x13"	Marine Galvanised Steel	26
S600W	S650W	23 ltrs (6 US Gals)	Horizontal	Rear	100 psi	13"x19"x13"	White Epoxy	26
S600EW		23 ltrs (6 US Gals)	Horizontal	Electric	100 psi	13"x19"x13"	White Epoxy	26
	S650E	23 ltrs (6 US Gals)	Horizontal	Electric	100 psi	13"x19"x13"	Marine Galvanised Steel	26
	S650EW-3000	23 ltrs (6 US Gals)	Horizontal	Electric	100 psi	13"x19"x13"	White Epoxy	26
S700	S750	23 ltrs (6 US Gals)	Horizontal	Rear	100 psi	13"x19"x13"	Stainless Steel	24
S700E	S750E	23 ltrs (6 US Gals)	Horizontal	Electric	100 psi	13"x19"x13"	Stainless Steel	24
F1100	F1150	42 ltrs (11 US Gals)	Horizontal	Front	100 psi	16"x22"x16"	Marine Galvanised Steel	34
F1100W	F1150W	42 ltrs (11 US Gals)	Horizontal	Front	100 psi	16"x22"x16"	White Epoxy	34
	F1150WSR	42 ltrs (11 US Gals)	Horizontal	Front	75 psi	16"x22"x16"	White Epoxy	34
F1200	F1250	42 ltrs (11 US Gals)	Horizontal	Front	100 psi	16"x22"x16"	Stainless Steel	32
S1100	S1150	42 ltrs (11 US Gals)	Horizontal	Rear	100 psi	16"x22"x16"	Marine Galvanised Steel	34
S1200	S1250	42 ltrs (11 US Gals)	Horizontal	Rear	100psi	16"x22"x16"	Stainless Steel	32
	H2050	76 ltrs (20 US Gals)	Horizontal	Rear	100 psi	16"x32"x16"	Marine Galvanised Steel	48
	H2050EW	76 ltrs (20 US Gals)	Horizontal	Electric	100 psi	16"x32"x16"	White Epoxy	48
	H2050-3000	76 ltrs (20 US Gals)	Horizontal	Electric	100 psi	16"x32"x16"	White Epoxy	48
	H2050EW-4500	76 ltrs (20 US Gals)	Horizontal	Electric	100 psi	16"x32"x16"	White Epoxy	48
H2200		76 ltrs (20 US Gals)	Horizontal	Rear	100psi	16"x32"x16"	Stainless Steel	47
	H2250E	76 ltrs (20 US Gals)	Horizontal	Electric	100 psi	16"x32"x16"	Stainless Steel	47
HF2000	HF2050	76 ltrs (20 US Gals)	Horizontal	Front	100 psi	16"x32"x16"	Marine Galvanised Steel	48
HF2200	HF2250	76 ltrs (20 US Gals)	Horizontal	Front	75 psi	16"x32"x16"	Stainless Steel	47
S1800	S1850	76 ltrs (20 US Gals)	Vertical	Front	100 psi	20.25"x20"x27"	Marine Galvanised Steel	46
S1800W	S1850W	76 ltrs (20 US Gals)	Vertical	Front	100 psi	20.25"x20"x27"	White Epoxy	46
	S1850EW	76 ltrs (20 US Gals)	Vertical	Electric	100 psi	20.25"x 20"x27"	White Epoxy	46
	S1850WSR	76 ltrs (20 US Gals)	Vertical	Front	75 psi	20.25"x 20"x27"	White Epoxy	46
S1900	S1950	76 ltrs (20 US Gals)	Vertical	Front	100 psi	20.25"x 20"x27"	Stainless Steel	45
S1900E		76 ltrs (20 US Gals)	Vertical	Electric	100 psi	20.25"x 20"x27"	Stainless Steel	45
	H2850ES-3000	106 ltrs (28 US Gals)	Horizontal	Electric	100 psi	16"x40"x16"	Stainless Steel	59
	H2850ES-4500	106 ltrs (28 US Gals)	Horizontal	Electric	100 psi	16"x40"x16"	Stainless Steel	59
	H2850EW-3000	106 ltrs (28 US Gals)	Horizontal	Electric	100 psi	16"x40"x16"	White Epoxy	59
	H2850EW-4500	106 ltrs (28 US Gals)	Horizontal	Electric	100 psi	16"x40"x16"	White Epoxy	59

SHOWERS AND FAUCETS





FAUCETS, INTERIOR SHOWERS AND DECK OR TRANSOM SHOWERS FOR ADDED LUXURY ONBOARD

Our extensive range of marine grade faucets and showers means we have the model to suit you, from lightweight ABS faucets to the award-winning Whale Twist innovative deck shower, Whale have you covered.

ELEGANCE FAUCET RANGE

LIGHTWEIGHT AND DURABLE ABS FAUCETS IDEAL FOR TIGHT SPACES

WARRANTY 1 YEAR

- ▶ Robust ABS construction
- ▶ Designed for use with all types of galley pumps
- ▶ Easily connects to Whale Quick Connect pipework
- ▶ Choice of single or mixer faucets



RT1210
ELEGANCE - COLD ONLY

SINGLE FAUCET COLD ONLY

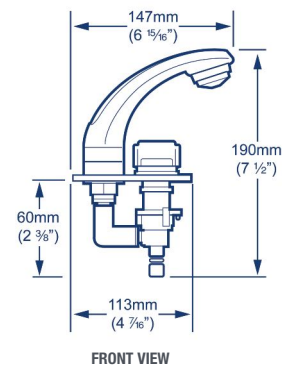

MIXER FAUCET STANDARD OUTLET

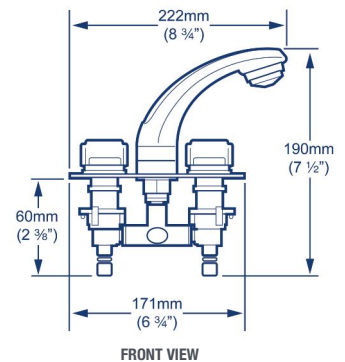

Model	Elegance Faucet	
PART NUMBER	RT1210	RT2210
Model	Single Faucet Cold only	Mixer Faucet Standard Outlet
Hose connection	Standard Connection 13mm (1/2") Threaded, Connection to Quick Connect 15mm: WX1532, Connection to Flexible Hose 13mm (1/2"): WX1532 or WX1584B	
Materials	Body: ABS, Spout and Valves: Acetal, Seals: Neoprene	
Materials in contact with fluid	Body: ABS, Spout and Valves: Acetal, Seals: Neoprene	
Service kits	AK5030 - Complete Serviceable Parts Kit, RT9000 - Microswitch Kit (2 switches)	
Accessories	RT9000 - Microswitch	
Base plate	113mm x 55mm (4 7/16" x 2 1/8")	171mm x 62mm (6 3/4" x 2 1/2")
Depth beneath surface	60mm (2 3/8")	60mm (2 3/8")

LIGHTWEIGHT AND DURABLE ABS SHOWERS

WARRANTY 1 YEAR

- ▶ Water saving rose allows temporary shut off to conserve water
- ▶ Designed for use with all types of galley pumps
- ▶ Connects to 3/8" or 1/2" hose connections
- ▶ Choice of single or mixer faucets
- ▶ Extra-long retractable hose for neat installation



Model	Elegance Faucet and Shower
PART NUMBER	RT2498
Model	Mixer Combination Faucet/Shower
Hose connection	Standard Connection 13mm (1/2") Threaded, Connection to Quick Connect 15mm: WX1532, Connection to Flexible Hose 13mm (1/2"): WX1532 or WX1584B
Materials	Body: ABS, Spout and Valves: Acetal, Seals: Neoprene
Materials in contact with fluid	Body: ABS, Spout and Valves: Acetal, Seals: Neoprene
Service kits	AS5133 - Replacement Handset 1/2" BSP Threaded (white) AS5146 - Replacement Hose Assembly 1.7m (5 3/8"ft) Long (white)
Accessories	RT9000 - Microswitch
Base plate	171mm x 62mm (6 3/4" x 2 1/2")
Depth beneath surface	80mm (3 1/8")

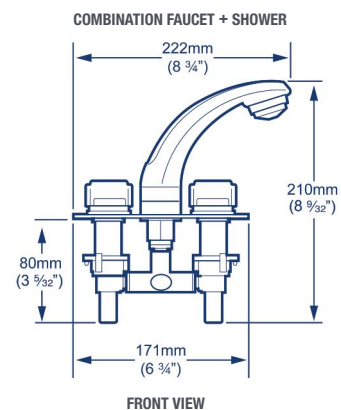

AN AWARD WINNING RADICAL INNOVATION IN DECK SHOWERS. THE TWIST PUTS CONTROL IN YOUR HANDS WITH ITS UNIQUE HANDSET INCORPORATING TEMPERATURE AND FLOW CONTROL IN A SINGLE EASY TO USE UNIT

- ▶ Robust ABS construction, easy to use - streamlined ergonomic design using high quality UV resistant ASA materials
- ▶ No lids or covers - Deck Protect end cap creates a splash proof seal
- ▶ Two housing options - horizontal discrete bezel style or vertical mounting that adapts to flat or curved surfaces
- ▶ Whale Twist Deck Shower is quick and easy to install
- ▶ Mixer models include a temporary shut off valve as standard

Model	Whale Twist	
PART NUMBER	DS0005	DS0006
Model	Cold only Flexible Hose	Mixer Hot and Cold Patented D Hose
Weight	0.13kg (0.3lbs)	0.2kg (0.45lbs)
Hose connection	3/8" BSP Female / 15mm Quick Connect Male	(1/2") Threaded Connection
Materials	Handset: ASA, Internal Parts: TPE, Nitrile, POM, Hose: Reinforced Polyurethane, Hose Connections: PBT, End Cap: Chromed ABS, Straight Housing: Chromed ABS, Glass-Filled Polypropylene, Angled Housing: ASA, Screws and Hose Clips: Stainless Steel	
Materials in contact with fluid	Handset: ASA, Internal parts: TPE, Nitrile, POM, Hose: Reinforced Polyurethane, Hose Connections: PBT, End Cap: Chromed ABS, Straight Housing: Chromed ABS	
Hose length	2.1m (6.9ft)	2.5m (8.2ft)
Accessories	AK0015 Twist stowage bag	
Retail individual pack contains	Whale Twist Deck Shower Cold only (Pale gray / white) with 2.1 m (6.9 ft) white hose. Includes straight housing (chrome) and angled housing (white) options	Whale Twist Deck Shower - Mixer (Pale gray / white) with 2.5 m (8.2 ft) white hose. Includes straight housing (chrome) and angled housing (white) options

WARRANTY 1 YEAR



HOW TO USE

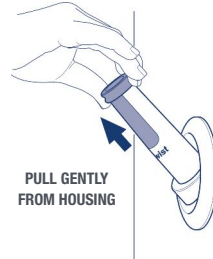

TWIST TO ADJUST TEMPERATURE AND FLOW

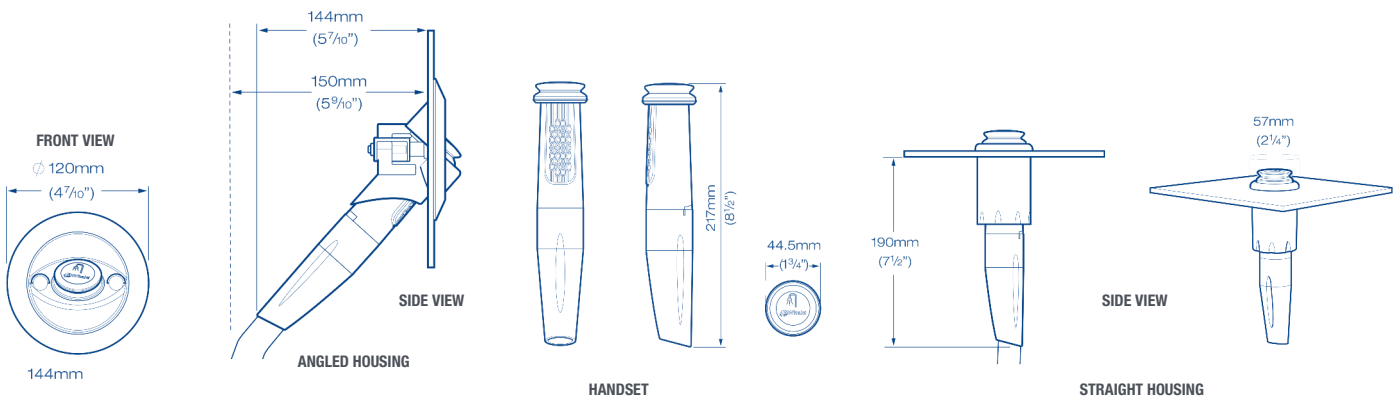
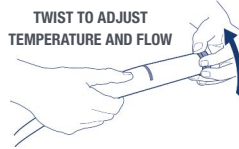

SWIM 'N' RINSE COMPACT DECK / TRANSOM SHOWER

IDEAL FOR INSTALLATION WHERE SPACE IS LIMITED ON DECK AND BEHIND THE BULKHEAD

WARRANTY 1 YEAR

- ▶ Simply swim and rinse without wasting water - press the trigger to only use the water you need
- ▶ Crisp and clean - chrome and white finish. Highest quality finish - stabilized PVC cover
- ▶ Extra-long hose allows you to fit in most convenient location on deck
- ▶ Simple installation - standard size circular holes to drill
- ▶ Standard connections - suitable for 3/8" BSP threaded connections / Whale Quick Connect 15mm plumbing

Model	Swim 'n' Rinse Compact Shower
PART NUMBER	RT3000
Model	Rubber Cover (cold only)
Weight	0.53kg (1.2lbs)
Hose connection	3/8" Adaptor x Female Adaptor 13mm (1/2") Connection to Quick Connect 15mm: WX1583B
Materials	Internal Components: Acetal Copolymer, Stainless Steel 304, Housing UV Stabilized Polypropylene, Cover: LDPE, Fixings: Stainless Steel
Materials in contact with fluid	Internal Components: Acetal Copolymer, Stainless Steel 304, Housing UV Stabilized Polypropylene
Service kits	AS5133 - Replacement Handset 1/2" BSP Threaded (white) AS5146 - Replacement Hose Assembly 1.7m (5 9/16" ft) Long (white)
Diameter of mounting hole	80mm (3 1/8")
Depth beneath surface	130mm (5 1/10")



SAVE WATER ON BOARD
- ONE TOUCH TRIGGER
HANDSET TO CONSERVE
WATER DURING SHOWERING



CLOSED COVER

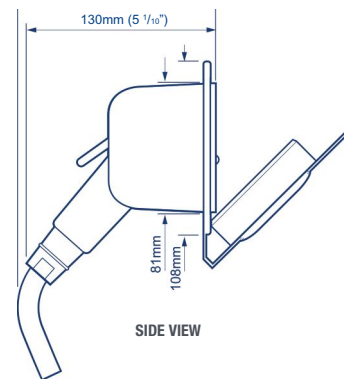

SIDE VIEW

RT3000
WHALE SWIM 'N' RINSE COMPACT SHOWER
RUBBER COVER (COLD ONLY)

SWIM 'N' RINSE TRANSOM SHOWER

LIGHTWEIGHT AND DURABLE ABS EXTERIOR SHOWER RANGE

WARRANTY 1 YEAR

- ▶ Designed for easy rinse down after swimming
- ▶ Fit in convenient locations on deck - extra long 2.1m (7ft) hose
- ▶ Save water on board - On/Off control on shower handset allows you to set temperature and only use the water you need
- ▶ Available with/without cover, neat hinged cover with latch to close
- ▶ Simple connection to either Whale Quick Connect 15mm pipework / 1/2" hose connection

Model	Swim N' Rinse Transom Shower	
PART NUMBER	RT2648	RT2658
Model	Hot and Cold Mixer (no cover)	Hot and Cold Mixer (cover included)
Weight	1.02kg (2.2lbs)	1.22kg (2.7lbs)
Hose connection	1/2" Male Threaded (BSP / NPT)	
Hose length	2.1m (7ft)	
Base plate	167mm x 292mm (6 1/2" x 11 1/2")	
Depth beneath surface	88mm (3 1/2")	

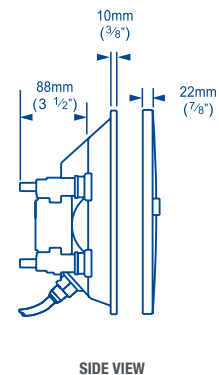
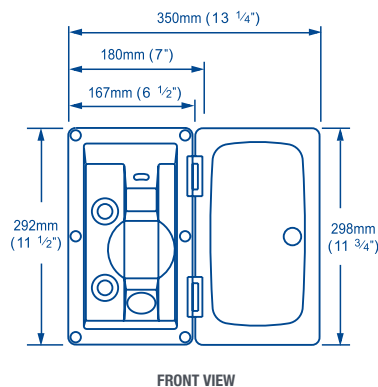

FRESHWATER ACCESSORIES

Fit Whale high quality pumps and accessories to ensure long term reliability from pump to faucet. Whale water filters, surge dampers, pressure switches and one-way valves are designed and manufactured to the highest quality specification. Combine these accessories with your Whale water pump for a home from home water supply on board.

INLINE WATER FILTERS

AQUASOURCE CLEAR WATER FILTER - WF1530

For refreshing tasting water on board

- ▶ Silverised carbon filter - removes nasty tastes and smells
- ▶ Connects directly to 15mm Quick Connect Plumbing / 1/2" (13mm) flexible hose (using stainless steel hose clips)



WF1530

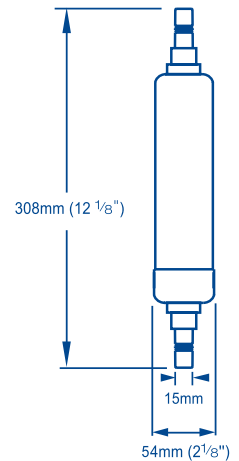

PUMP STRAINER

INLET STRAINER REPLACEMENT - AK1319

For use with Watermaster and Universal Pressure Pumps



AK1319

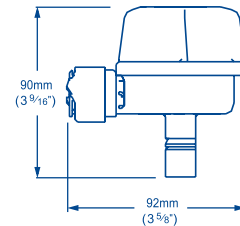

SIDE VIEW

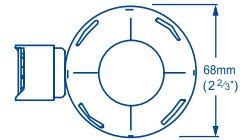

PLAN

INLINE PRESSURE SWITCH - WU7207

For use with submersible or inline self venting pumps in a pressurized water system

- ▶ Controls the pump by sensing changes in system pressure
- ▶ Suitable for: 12V d.c. 10 amps, 24V d.c. 5 amps
- ▶ Maximum pressure: 2 bar (30 psi)
- ▶ Materials: body: acetal, seals and valves: Nitrile, EPDM spring: phosphor bronze, fasteners: stainless steel

Note: must be mounted in a vertical position



WU7207



SIDE VIEW

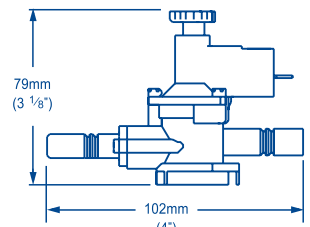

PLAN

EXPANSION VESSELS

SURGE DAMPER - WS7215

For a smooth constant water supply

- ▶ Capacity = 150 ml (0.03 US Gals)
- ▶ Connects directly to 15mm Quick Connect Plumbing / ½" 13mm flexible hose (using stainless steel hose clips)

Note: connect as close to the outlet of the pump as possible or as close to the outlet side of the pressure switch (if fitted)

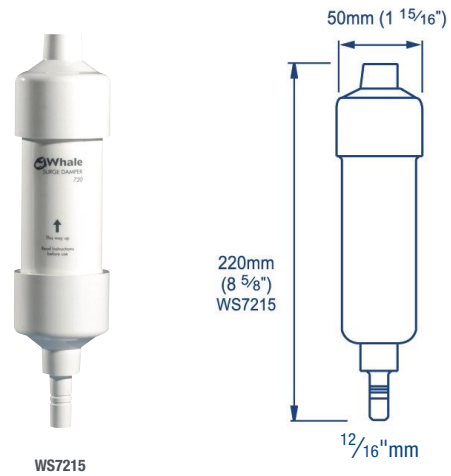

WS7215

PIPEWORK CONNECTIONS

ONE WAY CHECK VALVE - FV1227 FOR 13MM (½") FLEXIBLE HOSE (WHITE)

Fit inline to maintain prime for short periods

- ▶ Ideal for use with electric pumps
- ▶ Suitable for connection to 13mm (½") flexible hose
- ▶ Ensure the valve is installed with the arrow pointing in direction of water flow

Note: low restriction design will have a small drip return



FV1227

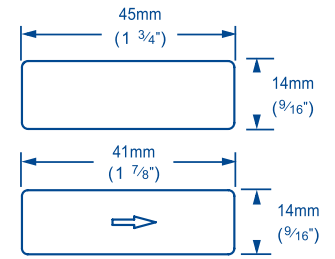

FV1227 SIDE VIEW

ACCESSORIES FOR TAPS AND SHOWERS

MICROSWITCH KIT - RT9000

For Elegance range and Swim 'n' Rinse Showers see pages 68, 69, 73



RT9000

ACCESSORIES - FOR DECK SHOWERS

TWIST STOWAGE BAG - AK0015

For use with Twist Deck Shower

- ▶ Neat storage of DS0005 / DS0006 - see pages 70 - 71

Note: this product is only suitable for use with 2.5m (8.2ft) hose Whale Twist models



AK0015

WASH DOWN









**EASY TO USE PRODUCTS THAT DELIVER GREAT
PERFORMANCE TO WASH DOWN YOUR DECK, INCLUDING
WHALE'S MOST POWERFUL WASH DOWN KIT YET**

Whale's high flow wash down pump range and ergonomic trigger spray handsets deliver great performance to wash down your deck.

HIGH PRESSURE WASH DOWN RANGE

TARGETED HIGH PRESSURE WASH DOWN RANGE FOR EFFECTIVE CLEANING

- ▶ Smooth constant flow
 - 13 ltrs/min (3.5 US Gals), 4.0 bar (60 psi)
 - 17 ltrs/min (4.5 US Gals), 4.8 bar (70 psi)
- ▶ Soft, non-slip trigger with deck protect nozzle, adjustable jet with push in fittings and dry coupling valve on / off, for a fine spray or a jet of water
- ▶ Easy stow - 7.6m (25ft) compact coiled hose with storage bag
- ▶ Elite Kit includes unique 4 in 1 deck fitting (hose connection, switch, fuse and sliding cover), for easy installation and IP65 rated protection

Product Type	Pump Spec	Description	Voltage	Part No.	
Pump Only	13 ltrs/min (3.5 US Gals), 4.0 bar (60 psi)	<ul style="list-style-type: none"> • Pump • Strainer • 2 x ½" barbed connections included 	12V	WD3517P	
	17 ltrs/min (4.5 US Gals), 4.8 bar (70 psi)		12V 24V	WD4517P WD4527P	
Pump and Trigger	13 ltrs/min (3.5 US Gals), 4.0 bar (60 psi)	<ul style="list-style-type: none"> • Pump • Strainer • Adjustable trigger with ergonomic handle & deck protect nozzle • 2 x ½" barbed connections included 	12V	WD3517T	
	17 ltrs/min (4.5 US Gals), 4.8 bar (70 psi)		12V 24V	WD4517T WD4527T	
Standard Kit - with Pump, Trigger and Hose	13 ltrs/min (3.5 US Gals), 4.0 bar (60 psi)	<ul style="list-style-type: none"> • Pump • Strainer • Adjustable trigger with ergonomic handle & deck protect nozzle • 7.6m (25ft) coil hose, storage bag and quick release hose connection • 2 x ½" barbed connections included 	12V	WD3517S	
	17 ltrs/min (4.5 US Gals), 4.8 bar (70 psi)		12V 24V	WD4517S WD4527S	
Elite Kit includes Pump, Trigger, Hose and 4 in 1 Deck Fitting	13 ltrs/min (3.5 US Gals), 4.0 bar (60 psi)	<ul style="list-style-type: none"> • Pump • Strainer • Adjustable trigger with ergonomic handle & deck protect nozzle • 7.6m (25ft) coil hose, storage bag and quick release hose connection • Deck fitting with switch, fuse, hose connection and sliding cover • 2 x ½" barbed connections included 	12V	WD3517E	
	17 ltrs/min (4.5 US Gals), 4.8 bar (70 psi)		12V 24V	WD4517E WD4527E	

WARRANTY 2 YEARS

- ▶ CE Certified
- ▶ ISO 10133
- ▶ IP65

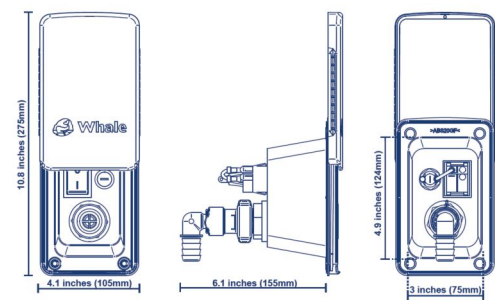

4 IN 1 FITTING

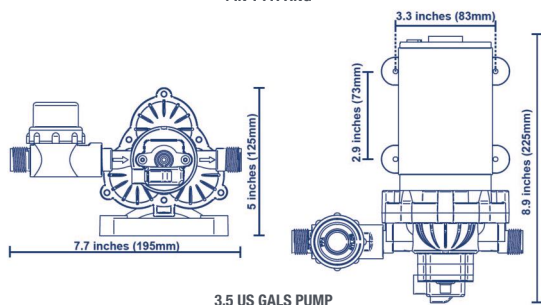

3.5 US GALS PUMP

SIDE VIEW

PLAN VIEW

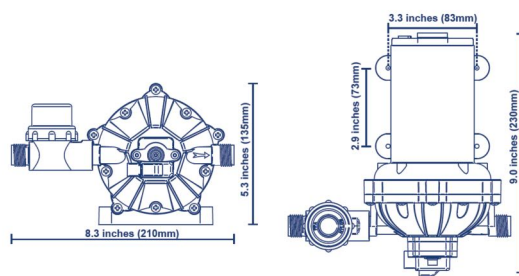

4.5 US GALS PUMP

SIDE VIEW

PLAN VIEW

PORTABLE PUMP KIT

THE VERSATILE SELF VENTING PORTABLE PUMPING SOLUTION

WARRANTY 1 YEAR

- ▶ ISO 10133
- ▶ ABYC H-23

- ▶ Wash down your boat with ease
- ▶ Great performance low voltage high flow submersible pump
- ▶ Easy to maintain with a wipe clean hose and nozzle
- ▶ Suitable for cold and warm water, diesel, light oils and water-based fluids including most water-based pesticides
- ▶ 3.75m (12.5ft) clear hose, nozzle with adjustable on / off, fine spray or a jet of water

Model	Self Venting Portable Submersible Pump Kit
PRODUCT NUMBER	GP1642
Weight	0.7kg (1.5lbs)
Voltage	12V d.c.
Fuse size	5 amps
Power connection	Crocodile clips and cigar lighter plug
Materials	Stainless Steel, Nitrile, PVC, Polypropylene, ABS

	Performance
PART NUMBER	GP1642
Discharge head	Flow Rate Per Minute and Current Draw
0m (0ft)	15.8 ltrs (4 US Gals) 3.8 amps
1m (3ft)	12.8 ltrs (3.5 US Gals) 3.5 amps



**KEEP STORAGE AREAS DRY WITH OUR WATERTIGHT ROBUST DESIGNS
- TRIED, TESTED AND TRUSTED FOR DECADES**

WARRANTY 1 YEAR

Aluminium models - suitable for sandy environments

TCL2

- ▶ Robust aluminium construction with locking lever
ideal for harsh marine environments

TCL4

- ▶ Reliable watertight seal

TCL4 CLEAR

- ▶ Allows easy inspection without having to open the locker

	Locker Doors		
Model	TCL2	TCL4	TCL4 Clear
PART NUMBER	LD2000	LD4000	LD4002
Diameter	228mm (9")	228mm (9")	228mm (9")
Aperture	179mm (7")	179mm (7")	179mm (7")
Materials	Body: Diecast Aluminium Alloy, Seal: Nitrile	Body: Polycarbonate, Locking Ring: Acetal, Seal: Nitrile	



LD2000



LD4000





LD4002



15 MM

-  **WX1502(B)**
15 mm Equal Tee
-  **WX1503(B)**
15 mm Equal Elbow
-  **WX1504(B)**
15 mm Equal Straight
-  **WX1508B**
End Plug (Brass)
-  **WX1509B**
Stem Adaptor 12 mm – 15 mm
-  **WX1511B**
Stem Adaptor 11 mm – 15 mm
-  **WX1512B**
Brass Back Plate
-  **WX1520B**
Adaptor 15 mm Female
15 mm Compression Fitting (Brass)
-  **WX1521(B)**
Stem Tee
-  **WX1522(B)**
Stem Elbow
-  **WX1546B**
End Stop
-  **WX1571(B)***
3 Way Valve (Brass)
-  **WX1573B***
Shut-off Valve (Brass)
-  **WX1574(B)**
Shut-off Valve
-  **WX1575B***
Stem Shut-off Valve (Brass)
-  **WX1582(B)**
Check Valve - Non Return Valve
(Brass)

THREADED 3/4"

-  **WX1516B**
Adaptor 3/4" BSP Male
-  **WX1542(B)**
Adaptor 3/4" BSP Female
-  **WX1552B**
Adaptor 3/4" Garden Hose
Thread (Green) Female

THREADED 3/8"

-  **CS1538B**
Adaptor 3/8" Plastic BSP Female
-  **WX1538**
Adaptor 3/8" BSP Female (Plastic)
-  **WX1538B**
Adaptor 3/8" BSP Female (Brass)
-  **WX1539B**
Stem Adaptor 3/8" Female (Brass)
-  **WX1563(B)**
Stem Adaptor 3/8" NPT Male (Brass)
-  **WX1583(B)**
Adaptor 3/8" BSP Male

THREADED 1/2"

-  **WX1080B**
Adaptor 1/2" BSP Male - 10 mm
Compression Fitting (Brass)
-  **WX1513B**
Adaptor 1/2" NPT Male
(Brass) - 15 mm
-  **WX1514B**
Adaptor 1/2" BSP Male - 15 mm
-  **WX1515(B)**
Faucet Tail Assembly Adaptor 1/2"
BSP Male - 15 mm
-  **WX1519B**
Flexible Heater Connector 1/2"
NPT Male 1/2" BSP Female
Length - 350 mm (14")
-  **WX1524(B)**
Stem Adaptor 1/2"
NPT Male (Brass)
-  **WX1531(B)**
Elbow Adaptor 1/2" BSP
Female - 15 mm
-  **WX1532(B)**
Adaptor 1/2" Female - 15 mm
-  **WX1533B**
Adaptor 1/2" BSP Female
(Brass) - 15 mm
-  **WX1534(B)**
15 mm Stem with None Return Valve
Adaptor 1/2" NPT Male (Brass)
-  **WX1536B**
Adaptor 1/2" BSP (Green)
(Short Wings) Female
-  **WX1567B**
1/2" NPT Male - 1/2" BSP Male Shower
Bulkhead Adaptor (Brass)
-  **WX1587(B)**
Stem Adaptor 1/2"
BSP Male - 15 mm

Part Numbers Explanation:

B Suffix: refers to items available only in bulk packed quantities for high volume production OEM use
 (B) Suffix: refers to items available in either retail packaging (e.g. WX1502) or in bulk packed quantities for high volume production OEM use (e.g. WX1502B).

Note: All brass connectors are lead-free and suitable for potable water unless marked with *

FLEXIBLE HOSE FITTINGS 1/2"



WX1544(B)
1/2" Hose Connector (Brass)



WX1584(B)
Stem Adaptor 1/2"
Flexible Hose Male



WX1585B
Tee 1/2" barb X 1/2" barb X 1/2" barb



WX1586B
Tee 1/2" barb X 15 mm WX X 1/2" barb



WX1591(B)
Stem Elbow 1/2" Flexible Hose

FLEXIBLE HOSE FITTINGS 3/4"



WX1555B
Tee 3/4" barb X 3/4" barb X 3/4" barb



WX1556B
Tee 3/4" barb X 15 mm
WX X 3/4" BARB



WX1557B
Tee 3/4" barb X 1/2" barb X 3/4" barb



WX1558B
Tee 1/2" barb X 1/2" barb X 3/4" barb



WX1592(B)
Stem Elbow 3/4" Flexible Hose



WX1593(B)
Stem Adaptor 3/4" Flexible Hose



WX2259B
Adaptor 22 Spigot X 3/4" barb

OTHER CONNECTIONS



WX1517B
3/16" X 24 UNEF Male Faucet Tail Adaptor
(Brass) suitable for Grohe Faucets



WX1535B
Stem Adaptor 1/8" Hose (Brass)
for Windscreen Washer



WX1537B
Stem Adaptor 1/4"
NPT Female (Brass)



WX1566B
Tank Fitting Assembly



WX2260B
End Stop 22 mm Spigot



WX1528(B)
Adaptor 3/8" - 15 mm

PLUMBING SAFETY FITTINGS



WX1595B*
Pressure Relief Valve
- 6 bar 1/2" Female



WX1599(B)
Thermostatic Mixer Valve 1/2" Male
(Brass) 15 mm and Check Valve /
Non-Return Valve
Note: This product is covered by 1
year warranty

FLEXIBLE HOSE FITTINGS OTHER



WX1548B
3/8" Hose Connector (Brass)



WX1597(B)
Stem Adaptor 3/8" Flexible Hose

COLOUR CODED TUBING



WX7152
Standard Semi-Rigid Pipework
15 mm Blue 10 m (33 ft)



WX7152B
Standard Semi-Rigid Pipework
15 mm Blue 50 m (164 ft)



WX7154
Standard Semi-Rigid Pipework
15 mm Red 10 m (33 ft)



WX7154B
Standard Semi-Rigid Pipework
15 mm Red 50 m (164 ft)



WX7156
Standard Semi-Rigid Pipework
15 mm Green 10 m (33 ft)



WX7156B
Standard Semi-Rigid
Pipework 15 mm Green 50 m (164 ft)



WX7162B
WHALEX Semi-Rigid Pipework 15 mm
High Performance Blue 50 m (164 ft)



WX7562B
WHALEX Semi-Rigid Pipework 15 mm
High Performance Blue 152 m (500 ft)



WX7164B
WHALEX Semi-Rigid Pipework 15 mm
High Performance Red 50 m (164 ft)



WX7564B
WHALEX Semi-Rigid Pipework 15 mm
High Performance Red 152 m (500 ft)



WX7166B
WHALEX Semi-Rigid Pipework 15 mm
High Performance Green 50 m (164 ft)



WX7168B
WHALEX Semi-Rigid Pipework 15 mm
High Performance White 15 m (49.2 ft)

TOOLS



WX7950
Pipework Cutters - must be used
to cut Whale Semi-Rigid Pipework



WX1569B
Pipework Mounting Clip (White)

WX1565(B)

Pipework Mounting Clip (Black)

WHALEX Pipework is NSF61 listed and has the benefits of a more scratch-resistant surface and greater durability.

QUICK CONNECT PLUMBING SYSTEM

Whale Quick Connect fittings provide fast and simple installation, ensuring high integrity, reliable, plumbing system solutions, specifically designed for use in mobile applications.

SAVE TIME AND MONEY BY USING WHALE QUICK CONNECT

- ▶ No pipe inserts or collet clips required, reducing part count, cost and installation time
- ▶ No special tools required to make a watertight connection
- ▶ 10 Year Warranty for peace of mind

RELIABLE AND DURABLE

- ▶ Unique 'Double Gripper' design provides secure lifelong pipework retention even at excessive pressures
- ▶ Innovative 'cage collet' eliminates leaks where fittings are installed close to tight bends
- ▶ High integrity single piece moulding improves the strength of the fittings
- ▶ Outer sleeve incorporates collet cover, preventing accidental pipework release
- ▶ Pipework includes measured cut marks, designed to be a visual guide to ensure that fittings are pushed fully home

WHALE QUICK CONNECT SEMI-RIGID PIPEWORK

- ▶ No pipe inserts required
- ▶ Whale Quick Connect color coded semi-rigid pipework is available in:
 - 12mm, 15mm, and 22mm OD
 - Standard or high performance WhaleX PE materials
- ▶ The pipework's flexibility enables tight bends to be formed, reducing fittings and installation time

MINIMUM BEND RADII RECOMMENDATIONS

All grades of Whale Quick Connect semi-rigid pipework are flexible and can be bent into a tight radius to facilitate easy installation. This reduces the number of fittings required and the total cost of the water system.

Minimum Bend Radius

Quick Connect 15mm Pipework

75mm (3")

Materials	
Whale Quick Connect Fittings	Glass-Filled Polypropylene
Whale Quick Connect Pipework	Polyethylene

Maximum Operating Conditions	Maximum Pressure	Maximum Temperature
Hot Water	6 bar (90 psi)	65°C (150°F)
Cold Water	12 bar (180 psi)	20°C (68°F)

Step 1.
Cut pipework to length by making a straight clean cut using Whale cutters WX7950 (see fig.1)

Step 2.
Simply push the pipework length into the fitting to the second internal stop (see fig.2)

Step 3.
To release pipework: Push back the gray collet into the fitting, then hold the collet in and pull out the pipework length (see fig.3 and 4)



FIG . 1

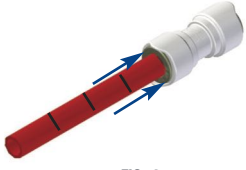

FIG . 3



FIG . 2

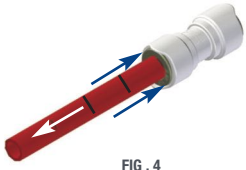

FIG . 4

FISH BOX/LIVEWELL





RELIABLE NON-CLOG FISHBOX AND BAITWELL PUMPS USING PROVEN GULPER TECHNOLOGY

Our non-clog, filter free Gulper electric waste pumps for fishbox and baitwell installations handle fish waste and ensure long term reliability. Unlike macerator pumps, they can run dry with no risk of motor burn out. Gulper valve technology has been built on more than 20 years of market leading pump technology for proven reliable waste management.

BUILT ON MORE THAN TWO DECADES OF MARKET LEADING PUMP TECHNOLOGY. UNLIKE MACERATOR PUMPS, GULPER VALVE TECHNOLOGY MEANS NO FILTERS, NO CLOGGING OR MOTOR BURN OUT, JUST RELIABLE WASTE MANAGEMENT.

- ▶ Gulper Grouper MK3 with 90° port orientation ideal as a direct macerator replacement in fishbox installations
- ▶ No impeller to clog or burn, non-choke valves - can easily handle fishbox waste
- ▶ Easy to install and maintain - 360° head rotation and choice of 1" (25mm) or 1½" (38mm) hose connections
- ▶ Long term durability - runs dry without damage
- ▶ Save battery - low power consumption

Model	Gulper Grouper Mk1		Gulper Grouper Mk2		Gulper Grouper Mk3 With 90° Head	
PART NUMBER	BP4572	BP4574	BP4672	BP4674	BP4772	BP4774
Weight	1.6kg (3.5lbs)					
Voltage	12V d.c.	24Vd.c.	12V d.c.	24V d.c.	12V d.c.	24V d.c.
Fuse size	10 amps	5 amps	10 amps	5 amps	10 amps	5 amps
Dry running current	5 amps	2.5 amps	4 amps	2 amps	4 amps	2 amps
Cable size	1.5mm ² (16AWG)					
Hose connection	25mm (1") or 38mm (1½")					
Materials	Pump Body: Aluminium, Glass-filled Nylon, Clamp Ring: Acetal, Diaphragm: Santoprene®, Valves: Nitrile®, Feet: EPDM, Gearwheel: Delrin, Fasteners: Stainless Steel, Brass					
Materials in contact with fluid	Glass-filled Nylon, Nitrile, Santoprene®, Stainless Steel					
Service kits	AK1557 Diaphragm and Valves, AS1562 - Clamping Ring					

Performance			
PART NUMBER	BP4572 / BP4574	BP4672 / BP4674	BP4772 / BP4774
Suction lift	0m (0ft)	0m (0ft)	1m (3ft)
Discharge head	1m (3ft)	1m (3ft)	1m (3ft)
Flow rate per minute	22 ltrs (5.8 US Gals)	18 ltrs (4.8 US Gals)	16 lts (4.2 US Gals)
Maximum suction lift	0.5m (1.5ft)	1m (3ft)	
Maximum discharge head	3m (10ft)		2m (6ft)
Maximum discharge head and suction lift (combined)	3m (10ft)		3m(10ft)

WARRANTY 2 YEARS

- ▶ CE Certified
- ▶ ISO 10133
- ▶ ISO 15083
- ▶ ISO 8846
- ▶ ABYC H-22
- ▶ IP45



GULPER GROUPE MK 3 WITH 90° HEAD
- IDEAL REPLACEMENT FOR MACERATORS



GULPER GROUPE MK1/MK2

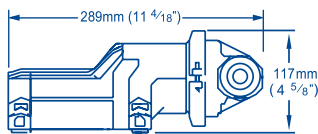

SIDE VIEW

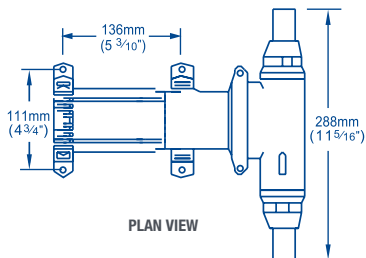

PLAN VIEW

GULPER GROUPE MK 3

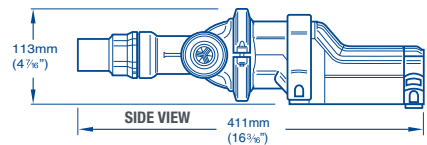

SIDE VIEW

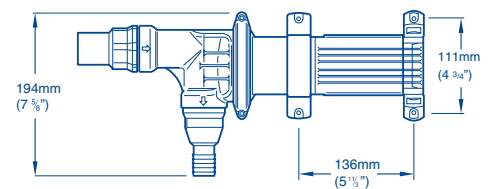

PLAN VIEW

UNLIKE MACERATOR PUMPS, GULPER VALVE TECHNOLOGY MEANS NO FILTERS, NO CLOGGING OR MOTOR BURN OUT, JUST RELIABLE WASTE MANAGEMENT

- ▶ Fishbox Discharge Pump
 - Handles fishbox waste
 - Easy to install in convenient locations
- ▶ Low amp draw means longer battery life
- ▶ Multi directional (360°) head for easy Installation
- ▶ Easy maintenance non-choke valve, no filter to clean or block
- ▶ Self-primers and runs dry without damage

Model	Gulper 320	
PART NUMBER	BP2052	BP2054
Weight	1.6kg (3.5lbs)	
Voltage	12V d.c.	24V d.c.
Fuse size	10 amps	5 amps
Cable size	1.5mm (16AWG)	
Hose connections	19mm (¾") or 25mm (1")	
Materials	Pump Head: Glass-filled Nylon, Valves: Nitrile, Diaphragm: Santoprene®	
Accessories	SB3422 (19mm / ¾") strainer (multi-directional port) included	
Service kits	AK2050 - Replacement Pump Head, AS1562 - Clamping Ring	

	Performance			
PART NUMBER	BP2052 / BP2054			
Hose size	19mm (¾")	25mm (1")	19mm (¾")	25mm (1")
Suction lift	0m (0ft)	0m (0ft)	1m (3ft)	1m (3ft)
Discharge head	1m (3ft)	1m (3ft)	1m (3ft)	1m (3ft)
Flow rate per minute	19 ltrs (5 US Gals)	17.5 ltrs (4.6 US Gals)	17.5 ltrs (4.6 US Gals)	15.5 ltrs (4.1 US Gals)

WARRANTY 3 YEARS

- ▶ CE Certified
- ▶ ISO 8849
- ▶ ISO 15083
- ▶ ISO 10133
- ▶ ISO 8846
- ▶ ABY H-22
- ▶ IP45



FISH BOX/LIVWELL

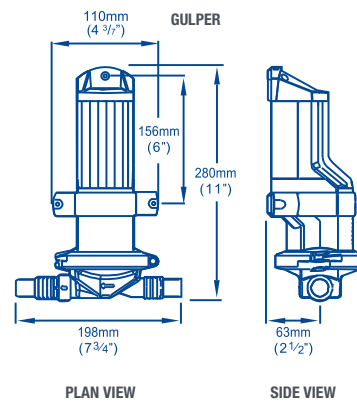
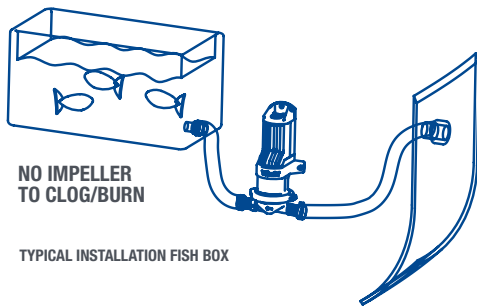

GRAY WASTE





WHALE'S LEGENDARY GULPER PUMP RANGE FOR TRULY FIT AND FORGET GRAY WASTE SOLUTIONS

Whale's Gulper pumps have led the way for over two decades in durability and non-clog valve technology, from simple one pump solutions to our range of automatic Intelligent Control tanks and pumps.

AUTOMATIC GRAY WASTE SYSTEM MANAGES WASTE FROM TWO DRAINS, ENSURING THE PUMP OPERATES ONLY WHEN REQUIRED WITH BUILT IN INTELLIGENT CONTROL

- ▶ Fully automatic - electrical signals are sent to the pump from the Two-Way Manifold IC, sensing only when water needs to be pumped away
- ▶ Saves space - fits where sumps or waste tanks are too large
- ▶ Easy to install and service free - no moving parts to clog or burn
- ▶ Fast drainage - high capacity up to 19 ltrs (5 US Gals) per minute with built in time delay
- ▶ Long life - self primes, runs dry without damage, soft start to protect the pump
- ▶ Low current controlled switching - no switch failure from high currents
- ▶ Kit includes plug and play Gulper IC pump and Two-Way Manifold IC with 4m (13ft) of cable

Model	MANIFOLD IC	
PART NUMBER	WM8284	WM8484
Weight	1.6kg (3.5lbs)	
Voltage	12V d.c.	24V d.c.
Fuse size	10 amps	5 amps
Cable size	1.5mm ² (16AWG)	
Hose connection	Barbed Connection 19mm (¾") and 25mm (1")	
Materials	Pump Head: Glass-Filled Nylon, Valves: Nitrile, Diaphragm: Santoprene®, Clamp Ring: Acetal, Feet: EPDM, Gear Wheel: Delrin®, Fasteners: Stainless Steel	
Materials in contact with fluid	Glass-filled Nylon, Santoprene®, Stainless Steel	
Service kits	AK2050 - Replacement Pump Head, AS1562 - Clamping Ring	

	Performance				Manifold IC	
PART NUMBER	WM8284 / WM8484				Cable length	4m (13ft)
Hose size	19mm (¾")	25mm (1")	19mm (¾")	25mm (1")	Control Voltage	5V d.c. via Gulper® IC
Suction lift	0m (0ft)	0m (0ft)	1m (3ft)	1m (3ft)	Current Draw	Low power 0.01 amps
Discharge head	1m (3ft)	1m (3ft)	1m (3ft)	1m (3ft)	Hose connections	25mm (1")
Flow rate per minute	19 ltrs (5 US Gals)	17.5 ltrs (4.6 US Gals)	17.4 ltrs (4.6 US Gals)	15.5 ltrs (4.1 US Gals)	Connectors	IP68 Waterproof Quick Connect 7 way (directly onto Gulper® IC)

For further guidance on the selection of the correct pump, please see page 122

WARRANTY 3 YEARS

- ▶ CE Certified
- ▶ ISO 8849
- ▶ ISO 15083
- ▶ ISO 10133
- ▶ ISO 8846
- ▶ ABYC H-22
- ▶ IP45

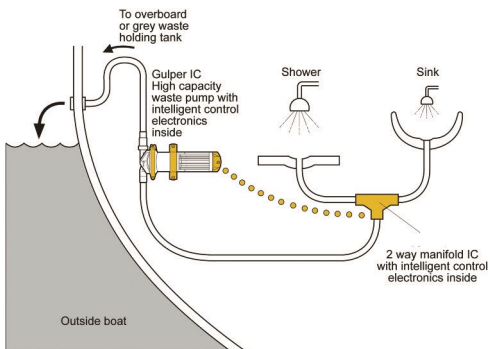

TYPICAL INSTALLATION

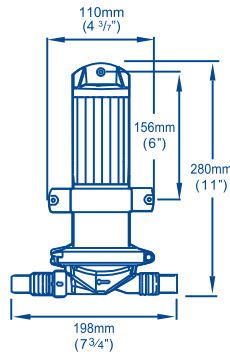

FRONT VIEW

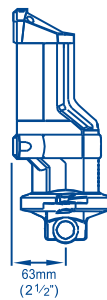

SIDE VIEW

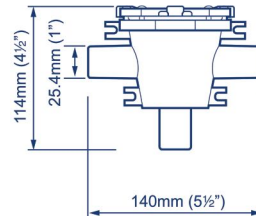

FRONT VIEW

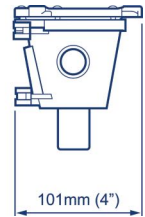

SIDE VIEW

AUTOMATIC SHOWER GULLEY WASTE SYSTEM MANAGES WASTE FROM A SINGLE GULLEY, ENSURING THE PUMP OPERATES ONLY WHEN REQUIRED WITH BUILT IN INTELLIGENT CONTROL

- ▶ Fully automatic - electrical signals are sent to the pump from the shower Gulley IC, sensing only when water needs to be pumped away
- ▶ Compact single shower automatic gulley saves space by removing the need for gravity drainage
- ▶ Easy to install and service free - no moving parts to clog or burn
- ▶ Fast drainage - high capacity up to 19 ltrs (5 US Gals) per minute with built in time delay
- ▶ Long life - self primes, runs dry without damage, soft start to protect the pump
- ▶ Low current controlled switching - no switch failure from high currents
- ▶ Noise reduction at gulley
- ▶ Kit includes plug and play Gulper IC electric waste pump and compact Gulley IC with 4m (13ft) cable for easy installation

Model	Gulley IC	
PART NUMBER	SG8284	SG8484
Weight	1.6kg (3.5lbs)	
Voltage	12V d.c.	24V d.c.
Fuse size	10 amps	5 amps
Cable size	1.5mm (16AWG)	
Hose connection	Barbed Connections 19mm (¾") and 25mm (1")	
Materials	Pump Head: Glass-filled Nylon, Valves: Nitrile, Diaphragm: Santoprene®, Clamp Ring: Acetal, Feet: EPDM, Gear wheel: Delrin®, Fasteners: Stainless Steel	
Materials in contact with fluid	Glass-filled Nylon, Santoprene®, Stainless Steel	
Service kits	AK2050 Replacement Pump Head, AS1562 - Clamping Ring	

	Performance				Gulley IC	
PART NUMBER	SG8284 / SG8484				Cable length	4m (12ft)
Hose size	19mm (¾")	25mm (1")	19mm (¾")	25mm (1")	Control voltage	5V d.c. via Gulper® IC
Suction lift	0m (0ft)	0m (0ft)	1m (3ft)	1m (3ft)	Current draw	Low power 0.01 amps
Discharge head	1m (3ft)	1m (3ft)	1m (3ft)	1m (3ft)	Hose connections	19mm (¾") or 25mm (1")
Flow rate per minute	19 ltrs (5 US Gals)	17.5 ltrs (4.6 US Gals)	17.4 ltrs (4.6 US Gals)	15.5 ltrs (4.1 US Gals)	Connectors	IP68 Waterproof Quick Connect 7 way (directly onto Gulper® IC)

For further guidance on the selection of the correct pump, please see page 122

WARRANTY 3 YEARS

- ▶ CE Certified
- ▶ ISO 8849
- ▶ ISO 15083
- ▶ ISO 10133
- ▶ ISO 8846
- ▶ ABYC H-22
- ▶ IP45

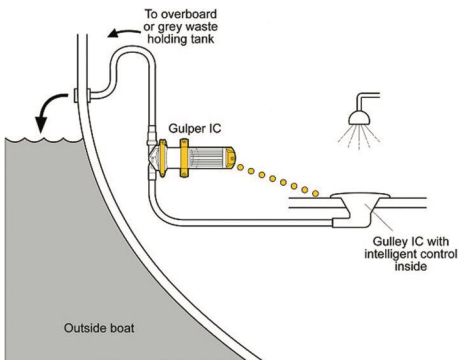

TYPICAL INSTALLATION

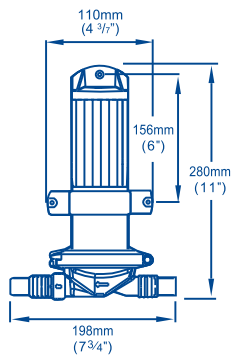

FRONT VIEW

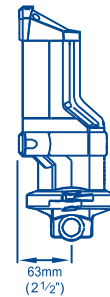

SIDE VIEW

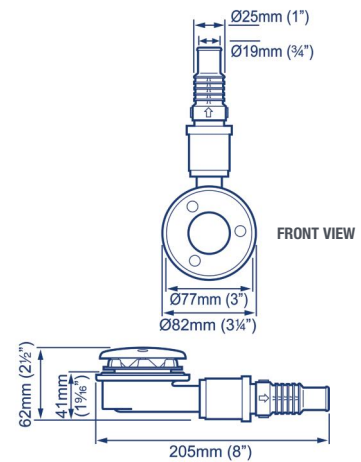

SIDE VIEW

GULPER VALVE TECHNOLOGY HANDLES SHOWER WASTE FROM MULTIPLE DRAINS - NO FILTERS AND NO CLOGGING, HIGH CAPACITY, FAST DRAIN

- ▶ Save space - one pump can be used for multiple drains with a gray waste tank
- ▶ Low current draw means longer battery life
- ▶ Multi directional (360°) head for easy installation
- ▶ Easy maintenance non-choke valve, no filter to clean or block
- ▶ Self-primers and runs dry without damage

Model	Gulper 320	
PART NUMBER	BP2052	BP2054
Weight	1.6kg (3.5lbs)	
Voltage	12V d.c.	24V d.c.
Fuse size	10 amps	5 amps
Cable size	1.5mm ² (16AWG)	
Hose connection	19mm (¾") or 25mm (1")	
Materials	Pump Head: Glass-filled Nylon, Valves: Nitrile, Diaphragm: Santoprene®	
Accessories	SB3422 (19mm / ¾") strainer (multi-directional port) included	
Service kits	AK2050 Replacement Pump Head, AS1562 - Clamping Ring	

	Performance			
PART NUMBER	BP2052 / BP2054			
Hose size	19mm (¾")	25mm (1")	19mm (¾")	25mm (1")
Suction lift	0m (0ft)	0m (0ft)	1m (3ft)	1m (3ft)
Discharge head	1m (3ft)	1m (3ft)	1m (3ft)	1m (3ft)
Flow rate per minute	19 ltrs (5 US Gals)	17.5 ltrs (4.6 US Gals)	17.5 ltrs (4.6 US Gals)	15.5 ltrs (4.1 US Gals)

For further guidance on the selection of the correct pump, please see page 122

WARRANTY 3 YEARS

- ▶ CE Certified
- ▶ ISO 8849
- ▶ ISO 15083
- ▶ ISO 10133
- ▶ ISO 8846
- ▶ ABYC H-22
- ▶ IP45



⚠ WARNING
 Gulper® 320 is not suitable for pumping diesel. For this application please contact Whale for information.

Now with barbed outlet (discharge) connections to allow a choice of connecting directly to either 3/4" (19mm) or 1" (25mm)

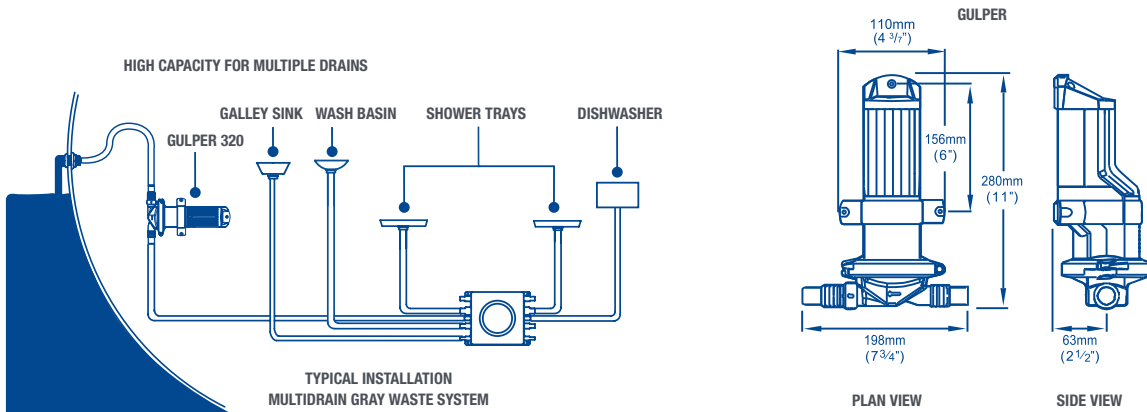

GRAY WASTE

RELIABLY PUMPS SHOWER WASTE INCLUDING HAIR AND GELS, VIRTUALLY UNBLOCKABLE VALVES, NO FILTER TO CLEAN

- ▶ Reliable operation - self-priming up to 3m (10ft)
- ▶ Double outlet valve ensuring continuous flow, will run dry without damage and pump a mixture of air and water
- ▶ Multi directional head - for ease of installation
- ▶ Low power consumption

Model	Gulper 220	
PART NUMBER	BP1552	BP1554
Weight	1.5kg (3.4lbs)	
Voltage	12V d.c.	24V d.c.
Fuse size	5 amps	2.5 amps
Cable size	1.5mm ² (16AWG)	
Hose connections	Inlet: 19mm (¾"), Outlet: Barbed connections 19mm (¾") or 25mm (1")	
Materials	Pump Body: Aluminium, Glass-filled Nylon, Clamp Ring: Acetal, Diaphragm: Santoprene®, Valves: Nitrile, Feet: EPDM Gearwheel: Delrin®, Fasteners: Stainless Steel, Brass	
Materials in contact with fluid	Glass-filled Nylon, Nitrile, Santoprene®, Stainless Steel	
Accessories	Gray Waste Tanks	
Service kits	AK1550 - Replacement Pump Head, AS1562 - Clamping Ring	

	Performance	
PART NUMBER	BP1552	BP1554
Maximum suction lift	3m (10ft)	
Maximum discharge head	3m (10ft)	
Maximum discharge head and suction lift (combined)	4m (13ft)	
Suction lift	0m (0ft)	1m (3ft)
Discharge head	1m (3ft)	1m (3ft)
Flow rate per minute	13.5ltrs (3.5 US Gals)	12.6ltrs (3.4 US Gals)

For further guidance on the selection of the correct pump, please see page 122

WARRANTY 2 YEARS

- ▶ CE Certified
- ▶ ISO 8849
- ▶ ISO 15083
- ▶ ISO 10133
- ▶ ISO 8846
- ▶ IP45



⚠ WARNING
 Gulper® 220 is not suitable for pumping diesel. For this application please contact Whale for information.

Now with barbed outlet (discharge) connections to allow a choice of connecting directly to either 3/4" (19mm) or 1" (25mm)

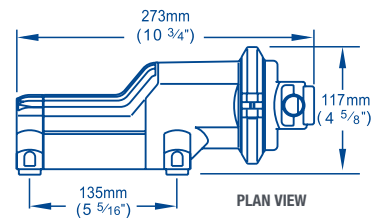
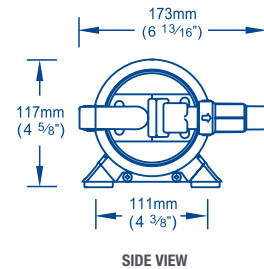
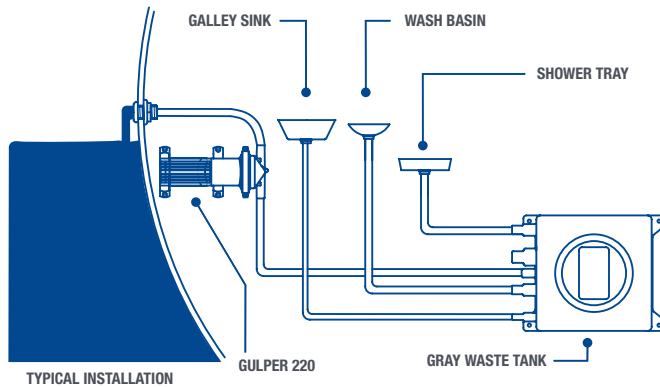

UNIQUE 'TRIPLE SEAL' LID ISOLATES ELECTRONICS FROM THE HARSH GRAY WASTE ENVIRONMENT FOR ADVANCED DURABILITY

- ▶ Integrated sensors for automatic pump control - solid state switch protected against water ingress
- ▶ Easy wiring - connect any 12V or 24V d.c. pump system (up to 20 amp with no relay required)
- ▶ Ports shaped for drilling accuracy (8 ltr and 20 ltr tanks only)
- ▶ Double switch models - second sensor can be wired to a high-level alarm or second pump
- ▶ Pumps can be top or side mounted on 20 ltr tank

8 LTRS / 2.1 US GAL MODEL



16 LTRS / 4.2 US GAL MODEL



20 LTRS / 5.3 US GAL MODEL



Models	Gray Waste Tanks										
PART NUMBER	GT0810B	GT0812B	GT0820B	GT0831B	GT1610B	GT1620B	GT1631B	GT2010B	GT2012B	GT2020B	GT2031B
Voltage	12V / 24V d.c.										
Capacity	8 ltrs (2.1 US Gals)				16 ltrs (4.2 US Gals)				20 ltrs (5.3 US Gals)		
No. of sensors	1	2	2	1	1	2	1	1	2	2	1
Electrical connections	Tinned wire ends		2 x Deutsch DT06-3S- P012	1x Deutsch DT06-3S- P012	Tinned wire ends	2 x Deutsch DT06-3S- P012	1x Deutsch DT06-3S- P012	Tinned wire ends		2 x Deutsch DT06-3S- P012	1x Deutsch DT06-3S- P012
Inlet hose connections	19mm (3/4") x 2, 25mm (1") x 3, 38mm (1 1/2") x 3				25mm (1") x 4, 38mm (1 1/2") x 4						
Outlet hose connections	19mm (3/4") x 1, 25mm (1") x 1				25mm (1") x 2						
Materials	Tank: MDPE, Seals: EPDM/Neoprene, Monprene®, Lid: Glass-filled Polypropylene, ABS, Polyurethane										
Service kits (Lid & sensor array)	AK1005	AK1008	AK1007	AK1006	AK1005	AK1007	AK1006	AK1005	AK1008	AK1007	AK1006

TYPICAL INSTALLATION



FITTER FRIENDLY - CLEAR VISUAL CUES FOR INSTALLATION

TYPICAL INSTALLATION

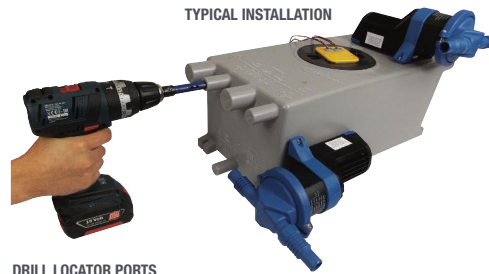

DRILL LOCATOR PORTS

WARRANTY 3 YEARS

- ▶ CE Certified
- ▶ ISO 10133
- ▶ ISO 8846



TRIPLE SEAL PROTECTED ELECTRONICS

TYPICAL INSTALLATION -
GULPER PUMPS AVAILABLE SEPARATELY

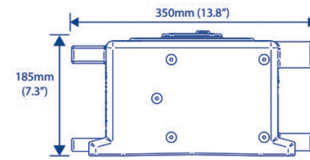
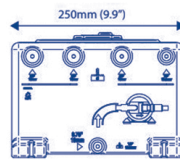
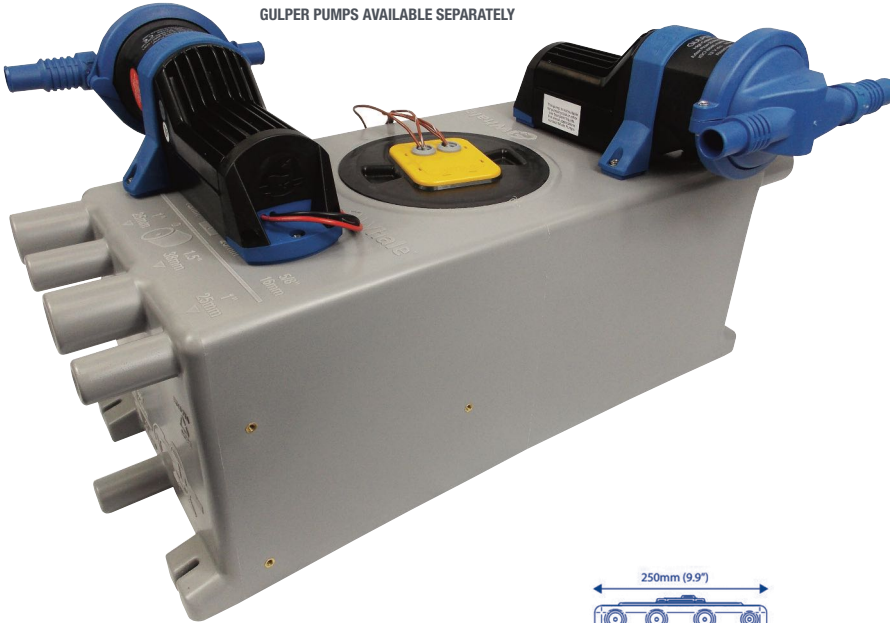

8ltrs (2.1 US gals) Tank Models

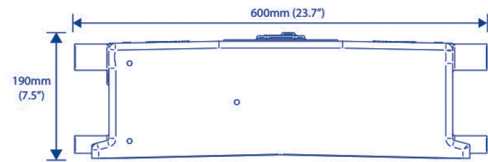
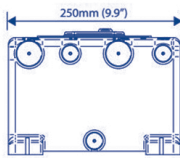

16ltrs (4.2 US gals) Tank Models

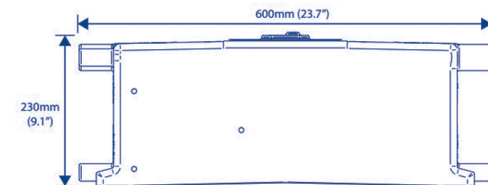
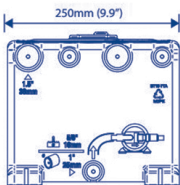

20ltrs (5.3 US gals) Tank Models

Figure 2 Grey Waste Tank Dimensions

SHOWER AND SINK WASTE HIGH CAPACITY SYSTEM

IDEAL FOR BOATS FROM 60FT FOR MANAGING LARGE AMOUNTS OF GRAY WASTE WATER

WARRANTY 1 YEAR

- ▶ Save space - pumps mounted onto tanks saves valuable space on board, allowing more flexibility for layouts
- ▶ Capacity - 100 ltrs (26.4 US Gals)
- ▶ Electronic switches
 - for automatic operation
 - no moving parts
 - no exposed contacts
 - max current draw 20 amp
- ▶ Clear inspection lid with 3 independent switches
 - Switch 1 - operates pump 1
 - Switch 2 - operates pump 2 when a higher volume of waste needs to be pumped out
 - Switch 3 - high level alarm



Model	Shower and Sink Waste High Capacity System
PART NUMBER	GW1033
Tank material	MDPE
Tank wall thickness	8mm
Tank dimensions (length x width x height)	830mm (33"), 530mm (21"), 240mm (9.4")
Pumps	2 x Gulper 320 (24V d.c.) 19 ltrs (5 US Gals) / minute each
Switches	3 x BE9003
Electrical connections	Deutsch
Inlet fittings	4 x 2" BSP thread
Plunger tube for manual pump	No
Vent	¾" Elbow

*Please note: this product is currently only available to boat builders - minimum order quantities apply - contact Whale Support for details

PRE-ASSEMBLED, EASY INSTALL KIT INCLUDES LEADING GULPER WASTE PUMP AND MULTI-PORT POLYETHYLENE TANK

WARRANTY 1 YEAR

- ▶ Includes 8 ltr (2.1 US Gal) tank and Gulper 220 pump
- ▶ Non-choke valves, proven debris handling - no filter required
- ▶ Can run dry without damage
- ▶ Automatic pump activation
- ▶ Robust polyethylene tank design (one piece roto-moulded), with pre-mounted pump to save on installation time



Model	Shower and Sink Waste System
GK1512	Kit includes 8 ltrs (2.1 US Gals) capacity gray waste tank and BP1552 Gulper 220 gray waste pump (12V d.c.)
GK1514	Kit includes 8 ltrs (2.1 US Gals) capacity gray waste tank and BP1554 Gulper 220 gray waste pump (24V d.c.)

COMPLETE YOUR SYSTEM

Fit Whale high quality pumps and accessories to ensure long term reliability throughout your gray waste system. Whale switches, diverter valves, and pipework connections are designed and manufactured to the highest quality specification. Combine these accessories with your Whale waste pumps for reliability and durability.

GRAY WASTE TANK ELECTRIC FIELD SENSOR SWITCH

- ▶ Electric field sensor automatically senses water levels and switches on the bilge pumps
- ▶ Automatically switches on when 51mm (2") of water is sensed and turns off when water drops below 13mm (½")
- ▶ BE9006 model - built in 30 second off delay for efficient operation, prevents cycle in small sump installations and enables lower drain than 13mm (½")

WARRANTY 1 YEAR

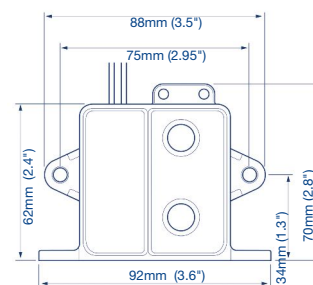

SIDE VIEW



Model	Electric Field Sensor Switch	Electric Field Sensor Switch (30 second time delay)
PART NUMBER	BE9003	BE9006
Voltage	12V d.c. or 24V d.c.	
Current	Suitable for up to 20 amps	
Standby current	0.008 amps	

DIVERTER VALVES ALLOWS ONE PUMP TO DRAW FROM 2 LOCATIONS

- DV5630 Diverter Valve 1" (25mm) connections
- DV5606 Diverter valve 1½" (38mm) connections

- ▶ Materials - Main Body: Acetal, Teflon, Handle: PTFE polyester
- ▶ Complies with US Coast Guard rules for type III Waste systems

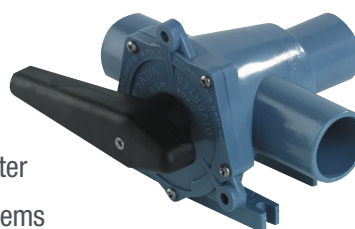

WARRANTY 5 YEARS

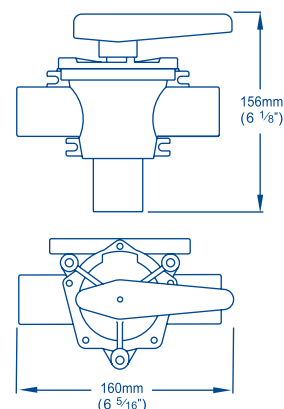

WHALE SUPPLY A WIDE RANGE OF ACCESSORIES DESIGNED SPECIFICALLY FOR USE WITH WHALE PUMPS, CREATING A COMPLETE SYSTEM SOLUTION FOR THE INSTALLER

Y PIECE

- ▶ Designed to enable two pumps to discharge through a single line
- ▶ Ideal for use when a diverter is not required

WARRANTY 1 YEAR

Model	Y Piece
PRODUCT NUMBER	YP6114
Pipe diameter	38mm (1½")
Materials	Polypropylene



ELBOWS

- ▶ Ideal for use in installations in confined spaces

Model	Elbows	
PRODUCT NUMBER	EB3364	EB3488
Pipe diameter	25mm (1")	38mm (1½")
Materials	Polypropylene	



NON-RETURN VALVES

- ▶ Extensive range now includes ¾" and 1½" models
- ▶ Provide an easy way to maintain prime in a suction or discharge line
- ▶ Designed to fit inline
- ▶ Suitable for use with manual or electric pumps

Model	Non Return Valves		
PRODUCT NUMBER	LV1215	LV1218	LV1219
Pipe diameter	25mm (1") / 38mm (1½")	25mm (1") / 28mm (1⅛")	19mm (¾") / 25mm (1")
Materials	Body: Glass-filled Polypropylene, Glass-filled Nylon, Valve: Nitrile		



Note: These specifications are retail items only. For details of our bulk pack range for boat builders and wholesalers - contact Whale Support.

BLACK WASTE





PRACTICAL, DEPENDABLE SOLUTIONS WHERE YOU REALLY NEED THEM

Fit Whale's manual and electric black waste pumps for reliable waste management onboard without the need for a macerator. Both the Gulper Toilet Pump and MK5 Sanitation Pump handle unmacerated waste and can pump dry, meaning no unwanted macerator failure and ensuring peace of mind onboard.

NON CLOG, NO FILTER WASTE PUMP BUILT ON MORE THAN TWO DECADES OF MARKET LEADING PUMP TECHNOLOGY. PUMPS UNMACERATED TOILET WASTE

- ▶ Virtually unblockable pumps - unmacerated toilet waste with ease
- ▶ Pumps a mixture of air and waste, runs dry without damage
- ▶ Pumps up to 18 ltrs (4.75 US Gals) per minute
- ▶ Rotatable inlet and outlet - allows you to install and maintain in awkward locations
- ▶ Self priming up to 3m (9.8ft) - mount the pump in the most convenient part of boat
- ▶ Ideal for holding tanks and vacuum systems

Model	Gulper Toilet Pump	
PART NUMBER	BP2652	BP2654
Weight	2.12kg (4.8lbs)	
Voltage	12V d.c.	24V d.c.
Fuse size	8 amps	4 amps
Dry running current	4.0 amps	2.0 amps
Cable size	1.5mm (16AWG)	
Hose connections	38mm (1½")	
Materials	Pump Body: Aluminum, Glass-filled Nylon, Clamp Ring: Acetal Diaphragm: Santoprene®, Valves: Nitrile, Gearwheel: Delrin, Feet: EPDM, Fasteners: Stainless Steel, Brass	
Materials in connection with fluid	Glass-filled Nylon, Santoprene®, Nitrile	
Service kits	AK1557 Diaphragm and Valves, AS1562 - Clamping Ring	

	Performance	
PART NUMBER	BP2652/BP2654	
Maximum suction lift	3m (10ft)	
Maximum discharge head	3m (10ft)	
Maximum discharge head and suction lift (combined)	3m (10ft)	
Suction lift	0m (0ft)	1m (3ft)
Discharge head	1m (3ft)	1m (3ft)
Flow rate per minute	17 ltrs (4.6 US Gals)	16.5 ltrs (4.4 US Gals)

For further guidance on the selection of the correct pump, please see page 122

WARRANTY 3 YEARS

- ▶ ISO 10133
- ▶ ISO 8846
- ▶ IP45



WARNING
IT IS IMPORTANT TO ENSURE THAT A SIPHON BREAK IS FITTED, WHERE DISCHARGE IS BELOW THE WATER LINE.

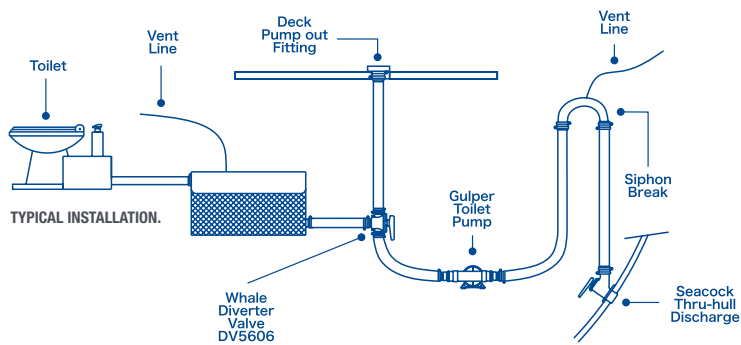

NOTE: WHERE DISCHARGE IS BELOW THE WATER LINE, A SIPHON BREAK MUST BE FITTED.

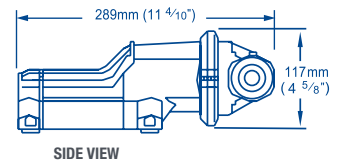

SIDE VIEW

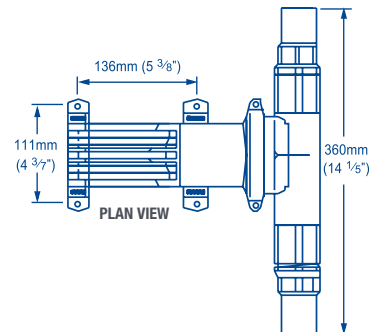

PLAN VIEW

MK5 SANITATION PUMP

MANUAL BLACK WASTE PUMP DESIGNED FOR TOILET FLUSH OR HOLDING TANK PUMP OUT. ENSURES TOTAL RELIABILITY IN BLACK WASTE MANAGEMENT

- ▶ Maximum performance - wide hose connections 38mm (1½"), 66 ltrs (17.5 US Gals) per minute
- ▶ Tough plastic housing keeps in nasty smells
- ▶ Large, virtually non-block valves
- ▶ Easy to clean (no tools required)
- ▶ Lightweight design for easy operation

Model	MK5 Sanitation Pump	
Model	Bulkhead	Thru Deck
PART NUMBER	BP0527	BP0535
Weight	1.17kg (2.6lbs)	
Hose connection	38mm (1½")	
Materials	Pump Body: Glass-Filled Polypropylene, Acetal, Diaphragm, Valves and Seals: Nitrile, Operating Lever: Acetal, Glass-filled Nylon, PVC, Handle, Spring and Fasteners: Stainless Steel	
Materials in connection with fluid	Glass-Filled Polypropylene, Acetal, Nitrile, Stainless Steel	
Service kits	AK8050 - Service Kit Contains: Diaphragms, Valves and Circlips	
Accessories	DP9906 - Deckplate Kit, DP9005 - Deck Ring (for BP0535 only)	

	Performance
PART NUMBER	BP0527 / BP0535
Maximum suction lift	4.5m (15ft)
Maximum discharge head	4.5m (15ft)
Suction lift	1m (3ft)
Discharge head	0.5m (1.5 ft)
40 strokes per minute	42 ltrs (11 US Gals)
70 strokes per minute	66 ltrs (17.5 US Gals)

WARRANTY 5 YEARS

▶ ISO 15083



⚠ WARNING
IT IS IMPORTANT TO ENSURE THAT A SYPHON BREAK IS FITTED, WHERE DISCHARGE IS BELOW THE WATER LINE.

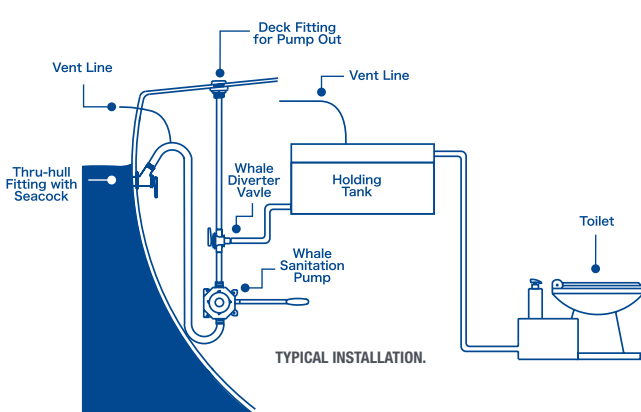

NOTE: WHERE DISCHARGE IS BELOW THE WATER LINE, A SIPHON BREAK MUST BE FITTED.

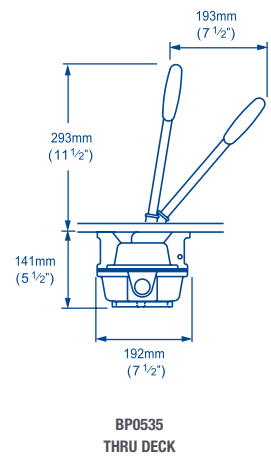
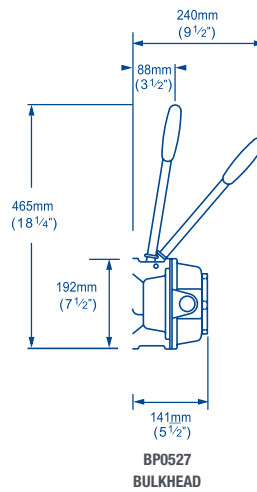

BLACK WASTE

COMPLETE YOUR SYSTEM

Fit Whale high quality pumps and accessories to ensure long term reliability throughout your black waste system. Diverter valves, and pipework connections are designed and manufactured to the highest quality specification. Combine these accessories with your Whale waste pumps for reliability and durability.

DIVERTER VALVE TO DIVERT FLOW TO OVERBOARD OR DECK PUMP OUT

WARRANTY 5 YEARS

DV5630 Diverter Valve 1" (25mm) connections

DV5606 Diverter valve 1½" (38mm) connections

- ▶ Materials - Main Body: Acetal, Teflon, Handle: PTFE polyester
- ▶ Complies with US Coast Guard rules for type III Waste systems

Note: Whale diverter valves are not designed to be installed in a pressurized system

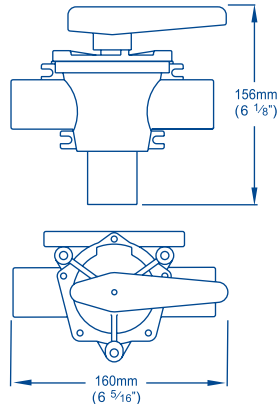
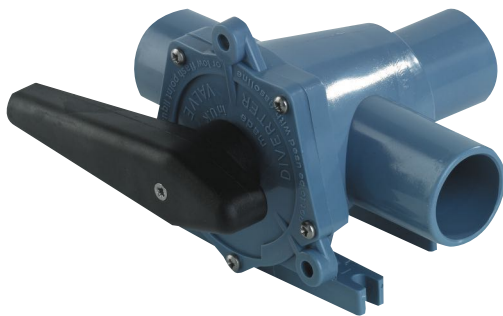

Y PIECE

WARRANTY 1 YEAR

- ▶ Designed to enable two pumps to discharge through a single line
- ▶ Ideal for use when a diverter is not required

Model	Y Piece
PRODUCT NUMBER	YP6114
Pipe diameter	38mm (1½")
Materials	Polypropylene



YP6114

ELBOWS

- ▶ Ideal for use in installations in confined spaces

Model	Elbows	
PRODUCT NUMBER	EB3364	EB3488
Pipe diameter	25mm (1")	38mm (1½")
Materials	Polypropylene	



EB3488

EB3364

NON-RETURN VALVES

- ▶ Extensive range now includes ¾" and 1½" models
- ▶ Provide an easy way to maintain prime in a suction or discharge line
- ▶ Designed to fit inline
- ▶ Suitable for use with manual or electric pumps

Model	Non Return Valves		
PRODUCT NUMBER	LV1215	LV1218	LV1219
Pipe diameter	25mm (1") / 38mm (1½")	25mm (1") / 28mm (1⅛")	19mm (¾") / 25mm (1")
Materials	Body: Glass-filled Polypropylene, Glass-filled Nylon, Valve: Nitrile		



LV1215



LV1218

LV1219



ELECTRIC MANUAL BILGE PUMPS

1. Select Boat Type	Brand		Whale		Attwood			HD			
	Model	Super Sub	Orca	Orca	Tsunami Bilge MK2	HD					
0-6m (0 - 20ft)	✓				✓						
	6-12m (20-40ft)	✓	✓	✓		✓	✓				
12-24m (40-80ft)		✓	✓	✓		✓	✓				
Open Flow Rate	650 US GPH 41 LPM	1100 US GPH 69 LPM	2000 US GPH 126 LPM	3000 US GPH 189 LPM	500 US GPH 32 LPM	800 US GPH 50 LPM	1200 US GPH 78 LPM	1700 US GPH 107 LPM	2000 US GPH 126 LPM		
	Orientation	Horizontal	Horizontal	Vertical	Vertical	Vertical	Vertical	Vertical	Vertical		
2. Flow Rate & Design	Images (not to scale)										
		Product Code	Low Profile Super 650	Low Profile Super 1100	Orca 2000	Orca 3000	Tsunami Bilge MK2, 1500	Tsunami Bilge MK2, 1800	Tsunami Bilge MK2, T1200	HD 1700	HD 2000
3. Select Pump Model	Product Code	12 V	SS5012(B)	SS1012(B)	BE2002	/	5606-1 / 5606-7	5608-1 / 5608-7	5612-1 / 5612-7	4730-1 / 4730-4	4760-1 / 4760-4
		24 V	N/A	SS1024(B)	BE2004	BE3004(B)	/	5609-1 / 5609-7	5613-1 / 5613-7	5613-1 / 5613-7	4770-1 / 4770-4
Outlet Size	19mm & 25mm (¾" & 1")	25mm & 28mm (1" & 1½")	28mm (1½)	28mm (1½)	19mm (¾")	19mm & 25mm (¾" & 1")	25mm & 28mm (1" & 1½")	28mm (1½)	28mm (1½)		
	Switches & Non Return Options	BE9003 Electric Field Switch, Non-Return Included	BE9003 Electric Field Switch, Non-Return Included	BE9003 Electric Field Switch, LV1218 Non-Return Valve	BE9003 Electric Field Switch, LV1218 Non-Return Valve	Included	Included	Included	BE9003 Electric Field Switch, LV1218 Non-Return Valve	BE9003 Electric Field Switch, LV1218 Non-Return Valve	
Availability	✓	✓	✓	✓	New			✓	✓		

* (B) suffix denotes version available as OEM version. Suffix -1 is OEM. Suffix -7 is retail

ELECTRIC AUTO BILGE PUMPS









Brand		Whale			Atwood							
1. Select Boat Type	Model	Super Sub Smart	Orca Auto	Bilge IC	Sahara MK2							
	0-6m (0 - 20ft)	✓			✓							
	6-12m (20-40ft)	✓	✓		✓	✓	✓					
	12-24m (40-80ft)		✓	Secondary only		✓	✓					
2. Flow Rate & Design	Open Flow Rate	650 US GPH 41 LPM	1100 US GPH 69 LPM	1300 US GPH 82 LPM	300 US GPH 19 LPM	500 US GPH 32 LPM	800 US GPH 50 LPM	1200 US GPH 78 LPM				
	Orientation	Horizontal	Horizontal	Vertical	Variable	Vertical	Vertical	Vertical				
	Images (not to scale)											
3. Select Pump Model	Product Code	Low Profile Super Smart 650	Low Profile Super Smart 1100	Orca Auto 1300	Bilge IC	Sahara MK2 S500	Sahara MK2 S800	Sahara MK2 S1200				
		Product Code ^x	12 V	24 V	SSS212(B)	SS1212(B)	BE1482	BE1484	SIR284	SIR484	5505-1 / 5505-7	5508-1 / 5508-7
	Outlet Size	19mm & 25mm (¾" & 1")	25mm & 28mm (1" & 1½")	25mm & 28mm (1" & 1½")	19mm & 25mm (¾" & 1")	19mm & 25mm (¾" & 1")	19mm & 25mm (¾" & 1")	19mm & 25mm (¾" & 1")	25mm & 28mm (1" & 1½")			
		Non Return Options	Included	Included	LVI218 Non-Return Valve	Included	Included	Included	Included			
	Availability	✓	✓	✓	✓	New						

^x(B) suffix denotes version available as OEM version. Suffix -1 is OEM. Suffix -7 is retail

MANUAL BILGE PUMP RANGE

1. Select Boat Type (by length)	Long Life Diecast Alloy Range		Tough and Lightweight Polypropylene Range				Compact Range		Portable Range							
	0 - 6m (0 - 20ft)	6 - 12m (20ft - 40ft)	12 - 24m (40ft - 80ft)													
2. Appliance, Performance & Port Size	PUMP USAGE															
	Emergency Bilge Pump Out	✓	✓	✓	✓	✓	✓	✓	✓	✓						
	Holding Tank Pump Out				✓	✓	✓	✓								
	Toilet Flush		✓			✓										
	Water Ballast Pump	✓	✓	✓	✓		✓									
	Approvals	Life Boats Approval • Approved by Lloyds (MCA)		Life Boats Approval • Approved by Lloyds (MCA) and USCG (MK5 Universal MCA - Size 2) (MK5 Double Acting - Size 3)												
	Performance Data (at 45 strokes per minute)	75 ltrs (20 US Gals)	41 ltrs (11 US Gals)	67 ltrs (18 US Gals)	42 ltrs (11 US Gals)	64 ltrs (17 US Gals)	25 ltrs (7 US Gals)	37.5 ltrs (9.9 US Gals)	32 ltrs (9 US Gals)	32.75 ltrs (9 US Gals)	43.5 ltrs (11.5 US Gals)					
	Port Size	1½" (38mm)	1½" (38mm)	1½" (38mm)	1½" (38mm)	1½" (38mm)	1" (25mm)	1½" (38mm)	1" (25mm)	1" (25mm)	1½" (38mm)					
	Images (not to scale)															
	3. Select Pump Model	Product Description														
On Deck		BP3000	BP3708	BP4402	BP0510	MH5570	BP9005 (Fixed Handle) BP9021 (Removable Handle)		/	/	/					
On Bulkhead		BP3010	BP3740	BP4410		MH5550	BP9013		BP0350	BP5012	/					
Thru Deck		BP3020				MH5560					BP1935 - Short Barrel					
Portable		/	/	/	/	/	/		/	/	BP1955 - Short Barrel					
Service Kits																
AK3051 - Service Kit for Gusher 30		AK3706 - Service Kit for Gusher 10 (Neoprene)		AK9003 - Gusher Titan Service Kit (Neoprene)		AK8050 - Service Kit for MK5 Universal		AK8060 - Service Kit for MK5 D Acting - contains: Diaphragms, Valves and Circlips AS8551 - Rocker arm assembly AS8552 - Clamping plate and nut kit		AK4400 - Service Kit for Gusher Urchin (Neoprene)		AK8035 - Service Kit for Compac 50		AK5010 - Service Kit for Smartball		
AK3714 - Service Kit for Gusher 10 (Nitrile)		AK9011 - Gusher Titan Service Kit (Nitrile)		AK8050 - Service Kit for MK5 Universal		AK4419 - Service Kit for Gusher Urchin (Nitrile)										

MANUAL AND ELECTRIC FRESHWATER PUMP RANGE

		Manual Freshwater Pumps						Electric Freshwater Pumps				
1. Select Boat Type (by length)	0 - 6m (0 - 20ft)	✓						✓				
	6 - 12m (20ft - 40ft)	✓						✓		✓ Refer to no. of outlets		
	12 - 24m (40ft - 80ft)											
	Outlets*	1	1	1	1	1	1	1-2	1-2			
2. Select Outlets & Performance	Pump Usage	Hand-operated Freshwater Pump			Foot-operated Freshwater Pump			Freshwater Impeller Pump				
	Flow Rate ltrs/min (US Gals./min)	8 ltrs (2 US Gals)	7 ltrs (1.85 US Gals)	8 ltrs (2 US Gals)	15 ltrs (4 US Gals)	15 ltrs (4 US Gals)	10 ltrs (2.6 US Gals)	13 ltrs (3.4 US Gals)	15 ltrs (4 US Gals)			
3. Select Pump Model	Images (not to scale)											
		Product Description	V Pump MK7	Flipper Pump MK4	Babyfoot	Gusher Galley MK3 - Right	Gusher Galley MK3 - Left	Standard Submersible/Inline	Premium Submersible/Inline	High Flow Submersible/Inline		
		Product Code	12 V	GP0650	GP0418	GP4618	GP0550	GP0551	GP1002	GP1352/GP1392	GP1652/GP1692	
			24 V						/	GP1354/GP1394	/	
		Accessories - Complete Your System		<p style="text-align: center;">Quick Connect Plumbing Range - Save Time and Money by using Whale Quick Connect wide range of fittings and pipework design. Ensures easy installation and re-usability of components. The two step installation procedure does not require special tools to make a watertight connection.</p>								
		Service Kits		AK0618 - V Pump Service Kit; AS0627 - Clamping Block Assembly	AK0618 - Service Kit for Flipper; AS0406 - Flipper Overhaul Kit	AK4615 - Kit for Babyfoot® Pump	AK0553 - Service Kit for Gusher® Galley MK3; AS0556 - Piston and Operating Kit	AK0553 - Service Kit for Gusher® Galley MK3; AS0556 - Piston and Operating Kit	/	/	/	
				<p style="text-align: center;">WU7207 - Pressure Switch Controls the pump - turning it on and off by sensing changes in water system pressure. Recommended for use with Whale submersible and in-line booster pumps.</p>								

*Example outlet types: Galley Faucet (Tap), Heads Faucet (Tap), Shower, Toilet Flush, Deck Wash, Transom Showers, Ice Maker, etc.

ELECTRIC FRESHWATER PUMP RANGE

Electric Freshwater Pressure Pump									
1. Select Boat Type (by length)	0 - 6m (0 - 20ft)	✓	✓	✓	✓	✓	✓	✓	✓
	6 - 12m (20ft - 40ft)	Refer to no. of outlets	Refer to no. of outlets	Refer to no. of outlets	Refer to no. of outlets	Refer to no. of outlets	Refer to no. of outlets	Refer to no. of outlets	Refer to no. of outlets
	12 - 24m (40ft - 80ft)								
	Outlets**	1-2	3-4	3-4	1-2	3-4	3-4	4-6	6-8
2. Select Outlets & Performance	Pump Usage	Freshwater Pump Range			Freshwater Accumulator Kit - Ensures smooth even flow to all outlets. Noise and vibration are reduced by preventing pump cycling				
	Maximum Running Pressure	2 Bar (30psi)	2 Bar (30psi)	3 Bar (45psi)	2 Bar (30psi)	3 Bar (45psi)	3 Bar (45psi)	3 Bar (45psi)	3 Bar (45psi)
	Flow Rate ltrs/min (US Gals/min)	8 ltrs (2 US Gals)	12 ltrs (3 US Gals)	12 ltrs (3 US Gals)	12 ltrs (3 US Gals)	12 ltrs (3 US Gals)	12 ltrs (3 US Gals)	18 ltrs (6 US Gals)	24 ltrs (6.3 US Gals)
	Images (not to scale)								
3. Select Pump Model	Product Description	Watermaster Pressure Pump**	Watermaster Pressure Pump**	Watermaster Pressure Pump**	12 ltr Pressure Pump & 2 ltr Accumulator	12 ltr Pressure Pump & 2 ltr Accumulator	12 ltr Pressure Pump & 8 ltr Accumulator	18 ltr Pressure Pump & 8 ltr Accumulator	24 ltr High Capacity 21 ltr Accumulator
	Product Code	FW0814	FW1214	FW1215	UF2214	UF2215	UF2015	UF8015	UF2415B
	Accessories - Complete Your System	PT0200 - 2 ltr Accumulator Tank - Ensures smooth even flow to all outlets. Noise and vibration are reduced by preventing pump cycling							
	Service Kits	AK1316 - Pump Head; AK1319 - Spare Filter; AK1329 - Spare Saltwater Filter	AK1316 - Pump Head; AK1319 - Spare Filter; AK1329 - Spare Saltwater Filter	AK1316 - Pump Head; AK1319 - Spare Filter; AK1329 - Spare Saltwater Filter	AK1316 - Pump Head; AK1319 - Spare Filter;	AK1316 - Pump Head; AK1319 - Spare Filter;	AK1316 - Pump Head; AK1319 - Spare Filter;	AK1316 - Pump Head; AK1319 - Spare Filter;	AK2415 - 12ltr, 12V d.c. Pump; AK2425 - 12ltr, 24V d.c. Pump; AK1314 - Spare Low Pressure Switch; AK1315 - Spare High Pressure Switch
					UF2224	UF2225	/	UF8025	UF2425B
					UF2214	UF2215	UF2015	UF8015	UF2415B
					UF2224	UF2225	/	UF8025	UF2425B
					UF2214	UF2215	UF2015	UF8015	UF3615B
					UF2224	UF2225	/	UF8025	UF3625B
					UF2214	UF2215	UF2015	UF8015	UF3615B
					UF2224	UF2225	/	UF8025	UF3625B
					UF2214	UF2215	UF2015	UF8015	UF3615B
					UF2224	UF2225	/	UF8025	UF3625B

*Example outlet types: Galley Faucet (Tap), Heads Faucet (Tap), Shower, Toilet Flush, Deck Wash, Transom Shower, Ice Maker, etc. **Can also be used with saltwater.

GULPER WASTE PUMP RANGE

Electric Waste Pumps								
1. Select Boat Type (by length)	0 - 6m (0 - 20ft)	✓	✓	✓	✓	✓		
	6 - 12m (20ft - 40ft)	✓	✓	✓	Refer to no. of outlets ✓	✓		
	12 - 24m (40ft - 80ft)	✓	✓	✓	✓	✓		
	Waste Outlets	1 <small>(or can be used with a Black Waste Tank for multiple outlets)</small>	1 <small>(or can be used with a Whale Gray Waste Tank for multiple outlets)</small>	1 <small>(or can be used with a Whale Gray Waste Tank for multiple outlets)</small>	2	1		
2. Select Outlets & Performance	Pump Usage	Black Waste	Gray Waste	Gray Waste	Gray Waste	Gray Waste		
	Flow Rate ltrs/min (US Gals/min)	18 ltrs (4.75 US Gals)	14 ltrs (3.5 US Gals)	19 ltrs (5 US Gals)	19 ltrs (5 US Gals)	19 ltrs (5 US Gals)		
	Images (not to scale)							
	Product Description	Gulper Toilet Pump	Gulper 220	Gulper 320	Gulper Gray IC Kit	Gulper Gully IC Kit		
3. Select Pump Model	Product Code	12 V	BP2552B	BP1552	BP2052	WM8284		
		24 V	BP2554B	BP1554	BP2054	WM8484		
	Accessories - Complete Your System	Black Waste Tank, Skin Fittings, Diverter Valve - DV5606, Hose Fitting Elbow 1½" - EB3488, Hose Fitting Y-Piece - YP6114		Gray Waste Tanks (8L, 16L, 20L), In-line Check Valve - LV1215, Skin Fittings, Hose Fitting Elbow 1" - EB3364, Hose Fitting Elbow 1½" - EB3488		Gray Waste Tanks (8L, 16L, 20L), Skin Fittings		
		In-line Check Valve - YP6114		In-line Check Valve - LV1215, Skin Fittings, Hose Fitting Elbow 1" - EB3364, Hose Fitting Elbow 1½" - EB3488, Hose Fitting Y-Piece - YP6114		In-line Check Valve - LV1215, Skin Fittings, Hose Fitting Elbow 1" - EB3364, Hose Fitting Elbow 1½" - EB3488, Hose Fitting Y-Piece - YP6114		
		Service Kits		AK1557 - Gulper Toilet Pump Service Kit	AK1550 - Gulper 220 Service Kit	AK2050 - Replacement Pump Head	AK2050 - Replacement Pump Head IC	AK2050 - Replacement Pump Head IC
		Service Kits						



DISCLAIMER

Any performance / specification figures shown have been calculated using standard testing procedures. Where maximum output is stated, such maximum output refers to pumps acting at zero lift and zero head. Actual performance may vary depending on the application, installation and environmental factors. Neither the accuracy nor completeness of the information contained in this or any Product literature is guaranteed by the Company and may be subject to change at its sole discretion. The Company may, at its sole discretion, change the technical performance, dimensions or appearance of any of its Products without prior notification to purchasers. The Company shall not be liable to a purchaser for any indirect or consequential loss or damage (whether for loss of profit, loss of business, depletion of goodwill or otherwise), costs, expenses or other claims for consequential compensation whatsoever (howsoever caused) which arise out of or in connection with the use of a Product. Where dimensions are stated, such dimensions are for guidance only. Inch measurements are conversions from millimetre dimensions and are shown to the nearest $\frac{1}{16}$ ". US gallons volumes are conversions from litres and are also shown for guidance purposes only to the nearest $\frac{1}{16}$ ".

Please contact the Company directly if precise measurements are required.

Please note: All products shown in this brochure are designed for use in marine vessels and are not suitable for installation in domestic applications.

Please note: All Whale electrical products must be installed and serviced by a qualified electrical engineer in accordance with the Whale appliance installation and operating instructions and appropriate electrical regulations and certifications.

©Copyright Whale 2024 - All rights reserved. Reproduction in whole or in part without permission is prohibited.

Whale Trade Names Whale®, Gusher®, Gulper®, Babyfoot® Whale Twist®, Deck Protect®, Smartbail®, Whale Watermaster®, Watermaster®, Whale IC® and Whale IC device® are registered trade names of Munster Simms Engineering Limited, Bangor, Northern Ireland, (trading as Whale).

Whale's policy is one of continuous improvement and we reserve the right to change specifications without prior notice. Illustrations are for guidance purposes only. Neither the accuracy nor completeness of the information contained in this or any Product literature is guaranteed by the Company and may be subject to change at its sole discretion.

Santoprene® is a registered trade name of Advanced Elastomer Systems, LP, an ExxonMobil Chemical Affiliate Delrin®, Teflon® and Neoprene are registered trade names of Dupont Neumeurs and Co. Monprene® is a registered trade name of Technore Apex.

Pictures courtesy of Sunseeker International and Brunswick Boat Group.

Munster Simms Engineering Ltd, 2 Enterprise Road,
Bangor, Co Down, N. Ireland, BT19 7TA

Whale - Support

Tel: +44 345 9090 913

Email: info@whalepumps.com

www.whalepumps.com

Whale - Support (The Americas)

Tel: +1 616 897 9241

Email: usasales@whalepumps.com

www.whalepumps.com

NORTH AMERICA

USA

Attwood Marine Products
1016 N. Monroe Street
Lowell, MI 49331
Tel: +1 616 897 9241
Email: usasales@whalepumps.com
www.whalepumps.com

Water Systems

CANADA (WEST)

Payne's Marine Supply Inc.
2120 Quadra Street, Victoria B.C.
V8T 4C5
Tel: +1 250 382 7722
Email: sales@paynesmarine.com
www.paynesmarine.com

CANADA (EAST)

Payne Distributors Inc.
2360 Industrial Street Burlington,
Ontario L7P 1A1
Tel: +1 905 332 8291
Email: sales@paynesmarine.com
www.paynesmarine.com

Water Heating

CANADA (WEST)

Western Marine Company
1494 Powell Street Vancouver,
BC, V5L 5B5
Tel: +1 604 253 7721
Email: sales@westernmarine.com
www.westernmarine.com

CENTRAL AND SOUTH AMERICA AND CARIBBEAN

ANTIGUA

Budget Marine Antigua
Jolly Harbour Boatyard, Bolans,
Antigua and Barbuda
Tel: +1 268-462-8753
www.budgetmarine.com

ARUBA

Budget Marine Aruba
Balashi 75-B, P.O. Box 162
Oranjestad, Aruba
Tel: +1 297-585-3796
www.budgetmarine.com

BONAIRE

Budget Marine Bonaire
Kaya Neerlandia 21
Kralendijk, Bonaire
Dutch Caribbean
Tel: +1 599-717-3710
www.budgetmarine.com

CURAÇAO

**Budget Marine Curaçao
- Caracasbaaiweg**
Caracasbaaiweg 202, Curaçao,
Dutch Caribbean
Tel: +5999-462-7733
www.budgetmarine.com

Island Water World

199 Caracasbaaiweg, Curacao
Tel: +5999-461-2144
Email: curacao@islandwaterworld.com
www.islandwaterworld.com

GRENADA

Budget Marine Grenada
True Blue,
St. Georges, Grenada
Tel: +1 473-439-1983
www.budgetmarine.com

Island Water World

Lagoon Road, St. Georges, Grenada
Tel: +1 473-435-2150
Email: grenada@islandwaterworld.com
www.islandwaterworld.com

Island Water World

Saint David Harbour, Grenada
Tel: +1 473-443-1028
Email: iwvstdavids@islandwaterworld.com
www.islandwaterworld.com

ST.LUCIA

Island Water World
Gros-Islet, Rodney Bay Marina,
Saint Lucia
Tel: +1 758-452-1222
Email: iwvsl.ltd@candw.lc
www.islandwaterworld.com

ST.MAARTEN

Budget Marine St. Maarten
Waterfront Road 25B P.O. Box 434 –
Philipsburg, Cole Bay, St. Maarten,
Dutch Caribbean
Tel: +1 721-544-3134
www.budgetmarine.com

Island Water World

Cole Bay Wellsburg St, Cole Bay,
St Maarten, Dutch Caribbean
Tel: +1 721-544-5310
Email: sales@islandwaterworld.com
www.islandwaterworld.com

Island Water World

Bobby's Marina,
Philipsburg, St. Maarten,
Dutch Caribbean
Tel: +1 721-543-7119
www.islandwaterworld.com

U.S. VIRGIN ISLANDS

Budget Marine St. Thomas
6198 Estate Frydenhoj
St. Thomas, VI 00802, U.S. Virgin Islands
Tel: +1 340-779-2219
www.budgetmarine.com

BRITISH VIRGIN ISLANDS

Budget Marine Tortola
Road Town, Tortola,
British Virgin Islands
Tel: 284-494-6588

TRINIDAD & TOBAGO

Budget Marine Trinidad
Western Main Road
Chaguaramas, Trinidad and Tobago
Tel: +1 868-634-2006
www.budgetmarine.com

EUROPE

AUSTRIA

Lankhorst-Hohorst GmbH
Bonifatiusstr. 411 D48432 Rheine
Tel: +49 5971 / 97 07-0
Email: info@lankhorst-hohorst.de
www.lankhorst-hohorst.de

BELGIUM

Lankhorst Taselaar B.V.
Komeet 13, 8448 CG Heerenveen
Tel: +31 (0) 320 27 4611
Email: sales@lankhorst-taselaar.nl
www.lankhorst-taselaar.nl

CROATIA

Unimar
Preluk 6^a – 51000 Rijeka
Tel: +385 (0)51 512 680
Email: unimar@unimar.hr
www.unimar.hr

DENMARK

Palby Marine A/S
Korsvej 3
6000 Kolding
Danmark
Tel: +45 75 88 13 11
E-mail: palby@palby.dk

FAROE ISLANDS

P/f Bátatænastan
Rundingar 20, Postboks 101,
FO-101 Tórshavn
Tel: +298 311735
Email: bt@bt.fo
www.bt.fo

FINLAND

OY Maritim AB
Veneentekijantie 1,
PO Box 46 00211 Helsinki 21
Tel: +358 (0)207 651 80
Email: maritim@maritim.fi
www.maritim.fi

FRANCE**Tecmar**

43 Rue Robert Geffré,
17000 La Rochelle
Tel: +33 546 50 50 46
Email: info@tecmar.fr
www.tecmar.fr

Seimi Equipement Marine

75 Rue Amiral Troude
29200 Brest
Tel +33 2 98 46 11 02
www.seimi-equipement-marine.com

Plastimo

21 rue de l'Amiral Dordelin
56100 LORIENT
contact@plastimo.com
Tél. +33(0)2 97 87 36 36

GERMANY**Lankhorst-Hohorst GmbH**

Bonifatiusstr. 411 D48432 Rheine
Tel: +49 5971 / 97 07-0
Email: info@lankhorst-hohorst.de
www.lankhorst-hohorst.de/

GIBRALTAR**M Sheppard & Co Ltd. Sheppard's Chandlery**

PO Box 899
34 Ocean Village Avenue
Waterport, Gibraltar
GX11 1AA
Tel +350 200 75148
Tel +350 200 77183
www.sheppard.gi

GREECE**Zois Efstathiou S.A.**

57 Posidonos Ave, 18344 Moschato
Tel: +30 21 9409828
Email: zois@zois.gr
www.zois.gr

HOLLAND**Lankhorst Taselaar B.V.**

Komeet 13, 8448 CG Heerenveen
Tel: +31 (0) 320 27 4611
Email: sales@lankhorst-taselaar.nl
www.lankhorst-taselaar.nl

HUNGARY**Marina Yacht Sport**

H-1032 Budapest,
San Marco u.56
Tel: +36 1 3228655
Email: office@marina.hu
www.marina.hu

ICELAND**Oliuverzlun Islands hf**

Höfðatún 2, 105 Reykjavík
Tel: +354 5151000
Email: olis@olis.is
www.olis.is

IRELAND**Union Chandlery Ltd.**

Doughcloyne Industrial Estate,
23 Sarsfield Rd., Garranedarragh,
Cork, T12 DR97
Tel: +353 21 4554334
Email: online@unionchandlery.com
www.unionchandlery.ie

ISRAEL**Yamit YSB Ltd.**

Marina Tel-Aviv, PO Box 6158
Tel-Aviv 61061
Tel: 972 3 5271779
Email: info@yamitysb.co.il
www.yamitysb.co.il

ITALY**Osculati SRL**

Via Pacinotti 12,
20054 Segrate Milano
Tel: +39 02 2699 111
Email: info@osculati.it
www.osculati.com

MALTA**International Marine Centre**

Testaferrata Street, Ta'Xbiex,
Tel: +356 2133 2747
Email: info@imc.com.mt
www.internationalmarinecentre.com

NORWAY**Watski A/S**

Kveldroveien 19 1407
Tel: +47(0) 22820060
Email: kontaktno@watski.com
www.watski.com

Norway Marine Supply AS

Postboks 777 Stoa
4808 Arendal
Norway
E:salg@nmsproff.no
T: +47 37 00 03 50
www.nmsproff.no

POLAND**Aura s.j.**

Przestrzenna 13 70-800 Szczecin
Tel: +48 915791900
Email: aura@aura.szczecin.pl
www.aura.szczecin.pl

SPAIN**Baitra**

Rúa Montes da Barxa.
Polígono Industrial Porto do Molle.
36350 Nigrán
Tel: +34 986 35 40 00
Email: baitra@baitra.com
www.baitra.com

Imnasa

Polígono Ferreries . Ctra, Fornells No.13
17457 Campllong Girona
Tel: +34 902 30 02 14
Email: imnasa@imnasa.com
www.imnasa.com

SWEDEN**Watski AB**

Kantyxegatan 14,
Malmö, 21 376
Tel: +46 40 6716700
Email: kundservice@watski.se
www.watski.se

Byggplast & Båtprylar Sverige AB

Lövbacksvägen 4
SE-141 71 Segeltorp
SWEDEN
T:+46 8 505 640 00
Email:info@byggplast-batprylar.se
www.byggplast-batprylar.se

SWITZERLAND**Bucher & Walt SA**

Route de Soleure 8
2072 St Blaise, Suisse
Tel: +41 32 755 95 00
Email: info@bucher-walt.ch
www.bucher-walt.ch

TURKEY**Artı Marin Mobil Enerji**

Sistemleri A.Ş.,
Sistemleri A.Ş.,
Guzleyali Mahallesi
İbrahim Hakki Cad. No: 42/ A
Pendik- Istanbul, Turkey
Tel: +90 216 493 93 01
Email: sales@artimarin.com
www.artimarin.com.tr

UNITED KINGDOM**Marathon Leisure Ltd.**

Teal Building, Northney Marina,
Hayling Island, Portsmouth
Hampshire PO11 0NH
Tel: +44 (0)2392 637711
Email: sales@marathonleisure.co.uk
www.marathonleisure.co.uk

Aquafax

Unit 1, Sundon Business Park,
Sundon Park Industrial Estate,
Dencora Way, Luton,
LU3 3HP
Tel: +44 (0) 1582 568700
Email: sales@aquafax.co.uk
www.aquafax.co.uk

DISTRIBUTORS

AFRICA

SOUTH AFRICA

Central Boating Pty, Ltd.
85 Bree St, Cape Town 8001
Tel: +27 21 4248026
Email: info@centralboating.com
www.centralboating.com

FAR EAST

JAPAN

Marine Services Kojima Co., Ltd.
2-1-12 Sachiura Kanazawa,
Yokohama City,
Kanagawa Pref. 236-0003
Tel: +81 45 790 3581
Email: sales@mskojima.co.jp
www.mskojima.co.jp

SINGAPORE

Marine International Pte Ltd
623 Aljunied Road, 04-10
Aljunied Industrial Complex
Singapore 389835
Tel: +65 6447 3004
Email: salesinfo@marine-intl.com.sg
www.marine-intl.com.sg

THAILAND

East Marine Co. Ltd.
23/159 Moo 2, Kohkaew,
Muang, Phuket 83000
Tel: +66 76 239 113
Email: sales@eastmarineasia.com
www.eastmarineasia.com

TAIWAN

DragonShore Ltd.
No. 2-3, SinSing Street
80347 Kaohsiung City
Tel: +886 (0) 7 521 3886
Email: admin@dragonshore.com
www.dragonshore.com

HONG KONG

Storm Force Marine Ltd.
601 Sunbeam Centre, 27 Shing Yi Street,
Kwun Tong Kowloon
Tel: +852 2866 0114
Email: sales@stormforcemarine.com
www.stormforcemarine.com

MALAYSIA

Marine Supplies Asia
LG-15, Royal Langkawi Yacht Club,
Jalan Dato Syed Omar,
07000, Kuah Langkawi Kedah
Tel: +60 0496-10696
Email: sales@MarineSuppliesAsia.com
www.marinesuppliesasia.com

PACIFIC

AUSTRALIA

BLA Pty Ltd.
BLA Head Office
131 Rivergate Place, Mararrie,
Queensland, 4172
Tel: +61 73907 5500
Email: sales@bla.com.au
www.bla.com.au

NEW ZEALAND

BLA Pty Ltd.
Unit 2, 76 Porana Road,
Glenfield, Auckland 0627
Tel: +64 9442 1717
Email: sales@bla.co.nz
www.bla.co.nz

NEW CALEDONIA

Marine Corail (Centre ville)
26 rue du Général Mangin
98800 Nouméa
Tel: +687 27 58 48
Email: info@marine-corail.nc
www.marinecorail.com

ABBREVIATIONS

A	Amps
ABYC	American Boat And Yacht Council (USA)
approx.	Approximately
AWG	American Wire Gauge
BMF	British Marine Federation
BSP	British Standard Pipe Thread
ft	Feet
g	Grams
gal/min	Gallons per Minute
ID	Inner Diameter
kg	Kilograms
lbs	Pounds
ltrs	Litres
ltr/min	Litres per Minute
m	Metres
mins	Minutes
ml	Millilitres
mm	Millimetres
NMMA	National Marine Manufacturers' Association (USA)
NPT	National Pipe Thread (USA)
OD	Outer Diameter
oz	Ounces
psi	Pounds per Square Inch
US gals	US Gallons
UV	Ultra Violet
V d.c.	Voltage (Direct Current)
"	Inches

ABBREVIATIONS - MATERIALS

ABS	Acrylonitrile-Butadiene Styrene
ASA	Acrylonitrile Styrene Acrylate
PTFE	Polyester Polyetra Fluoro Ethylene Filled Polyester
EPDM	Ethylene Propylene Diene Monomer
HDPE	High Density Polyethylene
MDPE	Medium Density Polyethylene
PA	Polyamide
PBT	Polybutylene Terephthalate
PC	Polyoxymethylene
PP	Polypropylene
POM	Polyoxymethylene
PVC	Polyvinyl Chloride
uPVC	Unplasticised Polyvinyl Chloride



Whale

2A Enterprise Road
Bangor, Co Down, BT19 7TA
Northern Ireland
Tel: +44 345 9090 913
whalepumps.com

© 2024 Navico Group. All Rights Reserved.
Navico Group is a division of Brunswick Corporation.

® Reg. U.S. Pat. & Tm. Off, and ™ common law marks. Visit www.navico.com/intellectual-property
to review the global trademark rights for Navico Holding AS.

Unauthorized copying or reproduction is a violation of applicable laws.

WHL-003-CAT-0924

Ref: MARINE BROCHURE_V6.0924